

2K22

SUPERIOR MAGNESIUM
ALLOY AND CARBON
TECHNOLOGY

SUSPENSION FORKS
REAR SHOCKS
E-BIKE SYSTEMS

SUNTOUR 

RIGHT HERE,

RIGHT NOW.



CONTENT

2K22

2K22 HIGHLIGHTS / TECHNOLOGY & FEATURES

HIGHLIGHTS & STORIES			
OVERVIEW _____	06	REAR SHOCKS	
FORK QUICK REFERENCE _____	08	TRIAIR2 _____	28
		EDGE PLUS _____	44
TECHNOLOGY & FEATURES _____	10	GLOSSARY _____	79
QSP PRODUCTS _____	10	FORK OVERVIEW _____	79
PCS SYSTEM _____	12	PCS CARTRIDGES _____	80
EQUALIZER SYSTEM _____	14	DAMPING ADJUSTMENT _____	82
		SPRING SYSTEM _____	84
SUSPENSION FORKS		ADJUSTABLE AIR CHAMBER	
RUX _____	16	VOLUME _____	85
DUROLUX _____	26	LOCK OUT LEVERS _____	85
AURON _____	40	STANCHION _____	87
ZERON _____	42	BOTTOM CASE COLORS _____	87
AXON _____	54	QLOC & THRU AXLES _____	88
GVX _____	56	HOLLOW CROWN _____	90
MOBIE _____	64	STANCHION DIAMETER _____	90
NCX _____	66	WHEEL SIZE _____	90
		STEERER TUBE _____	91
E-BIKE SYSTEM _____	70	BRAKE TYPE _____	91
		DISC BRAKE ROTOR SIZES _____	91
		HEAD LAMP MOUNT _____	92
		CABLE GUIDE _____	93
		SHORT FENDER _____	92
		FENDER MOUNTS _____	92
		STORIES	
		LA MINE _____	18
		MEGAVALANCHE _____	30
		PODIUM RUSH _____	46
		GET READY TO GRAVEL _____	58
		COMMUTING TO YOUR NEXT	
		ADVENTURE _____	68
		FURTHER CONTENTS	
		WERX FAMILY _____	72
		SPECIAL DEALER NETWORK _____	148
		SPECIAL SERVICE TOOLS _____	149
		WEBSITE GUIDE _____	150
		SOCIAL MEDIA GUIDE _____	151
		WORLDWIDE DISTRIBUTORS &	
		SUBSIDIARIES _____	152

WHAT'S ON THE COVER? TOM PIDCOCK WINS OLYMPIC GOLD IN THE MENS XC AT THE 2021 TOKYO OLYMPICS. READ THE "PODIUM RUSH" STORY FROM PAGE 46.
LOCATION TOKYO OLYMPICS 2021, IZU JAPAN
PHOTO ALEX BROADWAY/SWPIX



BACKGROUND PHOTO OLIVIER CUVET AND HIS CREW ARE PREPARING THE JUMP FOR THE MOMENT THE SUNLIGHT HITS THE HILL FOR THE PERFECT SHOT.
LOCATION COL DU GALIBIER, FRANCE
PHOTO HOSHI YOSHIDA

SPECIFICATIONS

SUSPENSION FORKS	94	XCT JR	123	NVX	138
RUX	97	XCE	124	NEX	139
DUROLUX	98	M 3010	125	CR	141
AURON	100	MOBIE 35	126		
AION	101	MOBIE 34	127	REAR SHOCKS	142
ZERON	102	MOBIE 45	128	TRIAIR 1	142
AXON WERX	103	MOBIE 25	129	TRIAIR 2	143
AXON	105	MOBIE A32	130	EDGE PLUS	144
EPIXON	107	MOBIE A32 CGO	130	EDGE	145
RAIDON	108	GVX	131	RAIDON	146
XCR	110	NRX	132		
XCM	117	NCX/TR-HSI	134	SUSPENSION SEAT POST	147
XCT	122	NCX 32	136	NCX	147

RIGHT HERE,

MAGIC MOMENTS HAPPEN WHEN YOU FOLLOW YOUR PASSIONS, DOING WHAT YOU LOVE. WHETHER IT'S THE GENTLE WARMTH OF THE FIRST SUN-RAYS ON YOUR SKIN COMMUTING TO WORK, OR THE SOAKED, MUDDIED, SATISFACTION OF THE WEEKEND'S EPICS. IT'S UNIQUE. IT'S PERSONAL. AND IT CAN HAPPEN TO ANYONE AND EVERYONE, ANYTIME, ALL OF THE TIME. THIS IS WHY WE'VE BEEN PASSIONATE ABOUT CYCLING SINCE 1912. WE ALL FEEL IT. THE SENSE OF FREEDOM AS WE BECOME ONE WITH THE BICYCLE AND OUR ENVIRONMENT. OUR BODIES AND BIKES COMBINED IN ERGONOMIC EFFICIENCY, GENUINE SUSTAINABILITY, ORIGINAL ENVIRONMENTAL PROTECTION. THROUGHOUT THE COVID-19 PANDEMIC, MANY PEOPLE HAVE TAKEN UP CYCLING FOR THE FIRST TIME. MANY OTHERS HAVE TAKEN THE CHANCE TO RECONNECT. FROM NEWBIES TO LEGENDS, WE ARE ALL PART OF THE HUMAN RACE, ALL RIDING ON THE SAME PLANET. AND WE ONLY HAVE NOW TO SAVE OUR PLANET. THERE'S NO TIME LIKE THE PRESENT. LET THE MAGIC HAPPEN. RIGHT HERE, RIGHT NOW.

RIGHT NOW.



RIDER OLIVIER CUVET
LOCATION COL DU GALIBIER, FRANCE
PHOTO HOSHI YOSHIDA

FOREWORD

// 2022

STANTOUR

2K22 HIGHLIGHTS & STORIES



DUROLUX38
EXTRA ROWDY

FREERIDE ENDURO

26



ZERON
RIDE MORE, SPEND LESS

ENDURO TRAIL

42

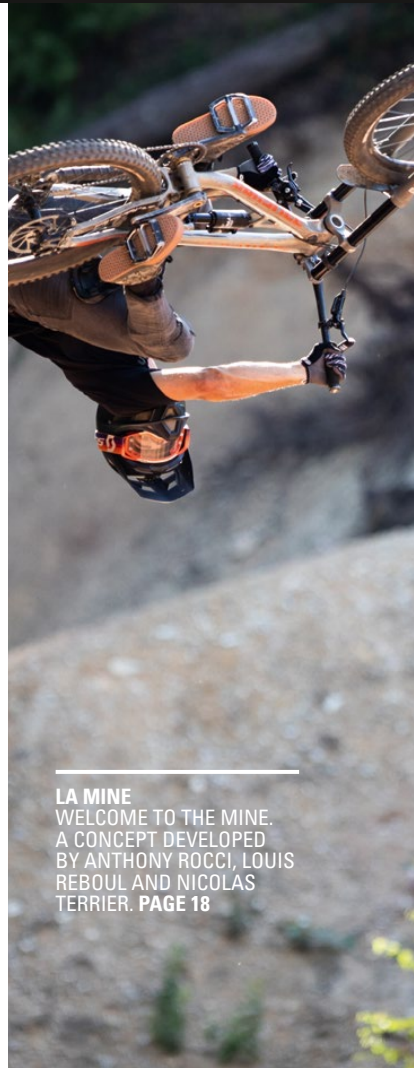

LA MINE
WELCOME TO THE MINE.
A CONCEPT DEVELOPED
BY ANTHONY ROCCI, LOUIS
REBOUL AND NICOLAS
TERRIER. PAGE 18



RUX
EVOLUTION OF
BIG MOUNTAIN

DOWNHILL FREERIDE

16



MEGAVALANCHE 2021
CELEBRATING THE 25TH
ANNIVERSARY. PAGE 30



GVX
EXPLORE THE ROAD
LESS TRAVELLED

GRAVEL

56

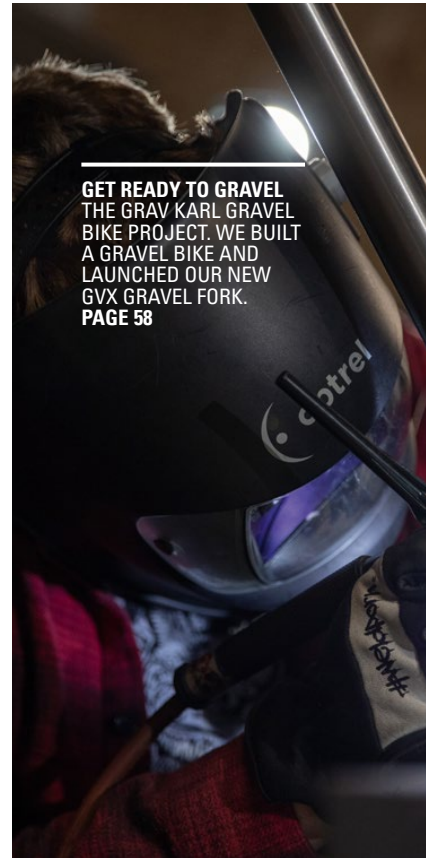

GET READY TO GRAVEL
THE GRAV KARL GRAVEL
BIKE PROJECT. WE BUILT
A GRAVEL BIKE AND
LAUNCHED OUR NEW
GVX GRAVEL FORK.
PAGE 58



AURON
TRAIL DETAIL

ENDURO TRAIL

40



GLOSSARY
THE SR SUNTOUR
TECH ALPHABET.
FROM PAGE 79

MOBIE
MODERN DESIGN FOR
THE E-EXPERIENCE

URBAN / UTILITY

64

NCX32
MODERN TREKKING

CROSS / TREKKING

66



TRIAIR2 ESTABLISH TRACTION

DOWNHILL FREERIDE ENDURO TRAIL

28



EDGE PLUS THE INLINE ANSWER

ENDURO TRAIL CROSS COUNTRY

44



AXON
BEYOND XC

CROSS COUNTRY

54

PODIUM RUSH
TOM PIDCOCK:
5TH, 2ND, 1ST, GOLD.
PAGE 46



SUSPENSION FORKS 2K22

QUICK REFERENCE

RIDER OLIVIER CUVET
LOCATION COL DU GALIBIER, FRANCE
PHOTO HOSHI YOSHIDA



FOLDOUT





RIDING STYLE

DOWNHILL

FREERIDE

ENDURO

TRAIL

CROSS COUNTRY

MODEL NAME	RUX38	RUX		DUROLUX38	DUROLUX36		AURON35		AION35		ZERON35		AXON34-WERX	AXON34-ELITE	AXON34		AXON32		AXON-WERX-F		AXON-WERX		AXON-ELITE	
	•	•	•	•	•	•	•	•	•	•	•	•			•	•								
WHEEL	27.5"	27.5"	26"	29"	29"	27.5"	29"	27.5"	29"	27.5"	29"	27.5"	29"	29"	29"	27.5"	29"	27.5"	29"	27.5"	29"	27.5"	29"	27.5"
BOOST	•			•	•	•	•	•	•	•	•	•	•	•	•	•	•	•						
STANCHION TUBE																								
TRAVEL (mm)	200	•	•	-	-	-	-	-	-	-	-	-	-	-	-	-	-	-	-	-	-	-	-	-
	180	-	-	•	•	•	•	•	•	•	•	•	•	•	•	•	•	•	•	•	•	•	•	•
	170	-	-	•	•	•	•	•	•	•	•	•	•	•	•	•	•	•	•	•	•	•	•	•
	160	-	-	•	•	•	•	•	•	•	•	•	•	•	•	•	•	•	•	•	•	•	•	•
	150	-	-	•	•	•	•	•	•	•	•	•	•	•	•	•	•	•	•	•	•	•	•	•
	140	-	-	•	•	•	•	•	•	•	•	•	•	•	•	•	•	•	•	•	•	•	•	•
	130	-	-	•	•	•	•	•	•	•	•	•	•	•	•	•	•	•	•	•	•	•	•	•
	120	-	-	•	•	•	•	•	•	•	•	•	•	•	•	•	•	•	•	•	•	•	•	•
	110	-	-	•	•	•	•	•	•	•	•	•	•	•	•	•	•	•	•	•	•	•	•	•
	100	-	-	•	•	•	•	•	•	•	•	•	•	•	•	•	•	•	•	•	•	•	•	•
	80	-	-	•	•	•	•	•	•	•	•	•	•	•	•	•	•	•	•	•	•	•	•	•



RIDING STYLE

CASUAL MTB

MODEL NAME	XCM34		XCM32				XCM32-ATB		XCM			XCM30-PLUS	XCM-JR	XCT30		XCT-PLUS		XCT-JR-L		XCT-JR		XCE			M3010				
	•	•					•	•																					
WHEEL	29"	27.5"	29"	27.5"	29"	27.5"	29"	27.5"	29"	27.5"	26"	24"	20"	29"	27.5"	24"	20"	24"	20"	24"	20"	29"	27.5"	26"	700C	26"	24"	20"	
BOOST	•	•	•	•								•																	
STANCHION TUBE																													
TRAVEL (mm)	130	•	•	-	-	-	-	-	-	-	-	-	-	-	-	-	-	-	-	-	-	-	-	-	-	-	-	-	-
	120	•	•	•	•	•	•	•	•	•	•	•	•	•	•	•	•	•	•	•	•	•	•	•	•	•	•	•	•
	100	•	•	•	•	•	•	•	•	•	•	•	•	•	•	•	•	•	•	•	•	•	•	•	•	•	•	•	•
	80	-	-	•	•	•	•	•	•	•	•	•	•	•	•	•	•	•	•	•	•	•	•	•	•	•	•	•	•
	70	-	-	-	-	-	-	-	-	-	-	-	-	-	-	•	-	-	-	-	-	-	-	-	-	-	-	-	-
	63	-	-	-	-	-	-	-	-	-	-	-	-	-	-	-	-	-	-	-	-	-	-	-	-	-	-	-	-
	60	-	-	-	-	-	-	-	-	-	-	-	-	-	-	•	-	-	-	-	-	-	-	-	-	-	-	-	-
	50	-	-	-	-	-	-	-	-	-	-	-	-	-	-	-	-	•	-	-	-	-	-	-	-	-	-	-	-
	40	-	-	-	-	-	-	-	-	-	-	-	-	-	-	-	-	-	•	-	-	-	-	-	-	-	-	-	•



RIDING STYLE

TRAIL

CROSS COUNTRY

MODEL NAME	AXON		EPIXON9			RAIDON34		RAIDON32		RAIDON32-LT	RAIDON			XCR34		XCR32			XCR			XCR32-LT		XCR32-ATB	
						•	•							•	•									•	•
WHEEL	29"	27.5"	29"	27.5"	26"	29"	27.5"	29"	27.5"	26"	29"	27.5"	26"	29"	27.5"	29"	27.5"	29"	27.5"	26"	24"	26"	29"	27.5"	
BOOST						•	•	•	•					•	•	•	•								
STANCHION TUBE																									
TRAVEL (mm)	140	-	-	-	-	•	•	-	-	-	-	-	-	• (COIL MAX.)	• (COIL MAX.)	-	-	-	-	-	-	-	-	-	
	130	-	-	-	-	•	•	-	-	-	-	-	-	-	-	-	-	-	-	-	-	-	-	-	
	120	•	•	•	•	•	•	•	•	•	•	•	•	•	•	•	•	•	•	•	•	•	•	•	
	110	-	-	-	-	-	-	-	-	-	-	-	-	-	-	-	-	-	-	-	-	-	-	-	
	100	•	•	•	•	•	•	•	•	•	•	•	•	•	•	•	•	•	•	•	•	•	•	•	
	80	•	-	-	-	-	•	•	-	-	•	-	-	-	-	-	-	-	-	-	-	-	•	•	
	70	-	-	-	-	-	-	-	-	-	-	-	-	-	-	-	-	-	-	-	-	-	-	-	
	63	-	-	-	-	-	-	-	-	-	-	-	-	-	-	-	-	-	-	-	-	•	-	-	



RIDING STYLE

URBAN / UTILITY

GRAVEL

CROSS

TREKKING

CROSS / TREKKING

TREKKING

URBAN / UTILITY

MODEL NAME	MOBIE35		MOBIE34		MOBIE34-CGO	MOBIE45		MOBIE25		MOBIEA32			GVX	NRX	NCX	NCX32		TR-HSI	NVX30		NEX-E25		NEX		CR85-E25		CR8	
	•	•	•	•	•	•	•	•	•	•	•	•	•			•	•		•	•	•	•			•	•		
WHEEL	29"	27.5"	700C	27.5"	20"	700C	27.5"	700C	27.5"	29"	27.5"	20"	700C	700C	700C	29"	27.5"	700C	29"	27.5"	700C	26"	700C	26"	700C	26"	700C	26"
BOOST	•	•			•																							
STANCHION TUBE																												
TRAVEL (mm)	160	•	•	-	-	-	-	-	-	-	-	-	-	-	-	-	-	-	-	-	-	-	-	-	-	-	-	-
	150	•	•	-	-	-	-	-	-	-	-	-	-	-	-	-	-	-	-	-	-	-	-	-	-	-	-	-
	140	•	•	-	-	-	-	-	-	-	-	-	-	-	-	-	-	-	-	-	-	-	-	-	-	-	-	-
	130	•	•	-	-	-	-	-	-	-	-	-	-	-	-	-	-	-	-	-	-	-	-	-	-	-	-	-
	120	•	•	-	-	-	-	-	-	-	-	-	-	-	-	-	-	-	-	-	-	-	-	-	-	-	-	-
	100	-	-	•	•	•	•	•	•	-	-	-	-	-	-	-	-	-	-	-	-	-	-	-	-	-	-	-
	80	-	-	•	•	•	•	•	•	-	-	-	-	-	-	-	-	-	-	-	-	-	-	-	-	-	-	-
	75	-	-	-	-	-	-	•	•	-	-	-	-	-	-	-	-	-	-	-	-	-	-	-	-	-	-	-
	63	-	-	-	-	-	-	•	•	-	-	-	-	-	-	-	-	-	-	-	-	-	-	-	-	-	-	-
	60	-	-	-	-	-	-	•	•	-	-	-	-	-	-	-	-	-	-	-	-	-	-	-	-	-	-	-
	50	-	-	-	-	-	-	-	-	-	-	-	-	-	-	-	-	-	-	-	-	-	-	-	-	-	-	-
	40	-	-	-	-	-	-	-	-	-	-	-	-	-	-	-	-	-	-	-	-	-	-	-	-	-	-	-

RIDE MORE



QSP IS APPLIED THROUGHOUT OUR PRODUCT LINE AND HERE ARE SOME EXAMPLES

- Easy travel changes in both suspension forks and rear shocks
- Integrated fenders
- Sealed, fully serviceable cartridges
- Minimal number of tools needed to service your SR SUNTOUR products
- Simple, clean and efficient lubrication with no messy oil bath
- Faster and easier service than our competitors.
- Lubrication/air burp valves on the RUX and DUROLUX for consistent runs
- Easy to install air volume spacers to customize your ride for your terrain



WATCH THE QSP
QUICK SERVICE
PRODUCT VIDEO

Learn more at www.srsuntour.com

WRENCH LESS



QSP - QUICK SERVICE PRODUCTS

Refined simplicity is our guiding principle. »High performance made simple« is the foundation of every one of our developments. Our PCS cartridge system is fully synchronized with our approach to applying simplicity to our designs. It not only aims to be technologically sophisticated but also to be user-friendly and low maintenance. Setup and maintenance are quick and easy and at a lower cost. All parts can be disassembled and the system can be bled and re-assembled again without the use of special tools. We call them QSP - Quick Service Products. Offering quick service and state of the art technology to our customers across all levels of riding is the philosophy behind QSP.



WATCH THE
PCS VIDEO

Learn more at www.srsuntour.com

PCS – PISTON COMPENSATOR SYSTEM

MORE TRACTION, CONTROL AND CONSISTENCY



- 01 Low speed compression
- 02 High speed compression

- 03 Air
- 04 PCS avoids vacuum effect
- 05 Oil (Red and blue marked area)
- 06 Piston management of high / low speed compression

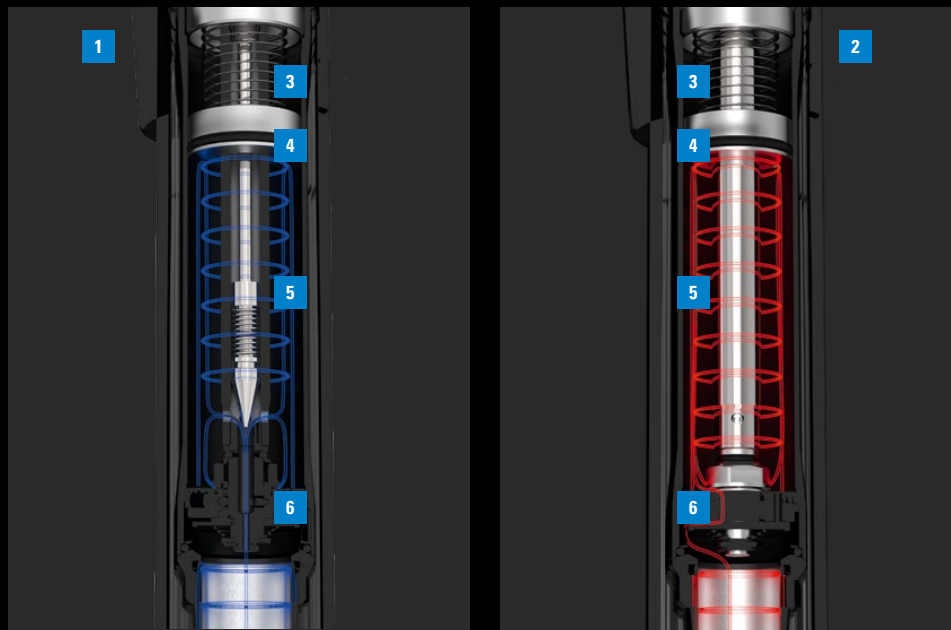

PERFORMANCE

Performance thru Controlled Speed. We believe we have developed a refined damper platform that can perform at any riding level, functions simply and follows our QSP philosophy.

CONTROL

PCS is 17 years of constant refinement within our cartridge science program. PCS is a simple and repeatable way, to reduce cavitation (air and oil mixing, creating pressure, building bubbles) inside the cartridge. This separation significantly reduces cavitation, which provides consistent and predictable damping performance at a WC DH level as well as throughout an entire season of ambitious riding.

LONGEVITY

Performance to us needs to be proven in the long run. Single cartridges with more than 200,000 cycles on our testing machines and countless hours with our WERX team have proven that our PCS is built to ride more hours and spend less time in a stand. But when the time comes for some fork care, service must be possible, quick and easy. All parts can be disassembled and the system can be bled and re-assembled again without the use of special tools. Quick Service Product (QSP) is our approach to apply simplicity to our designs.



WATCH THE
DUROLUX EQ
VIDEO

Learn more at www.srsuntour.com

EQ EQUALIZER SYSTEM

FOR PRECISE & EFFORTLESS TUNING



- 01 Positive air chamber
- 02 Transfer port
- 03 Negative air Chamber
- 04 Positive air pressure
- 05 Negative air pressure

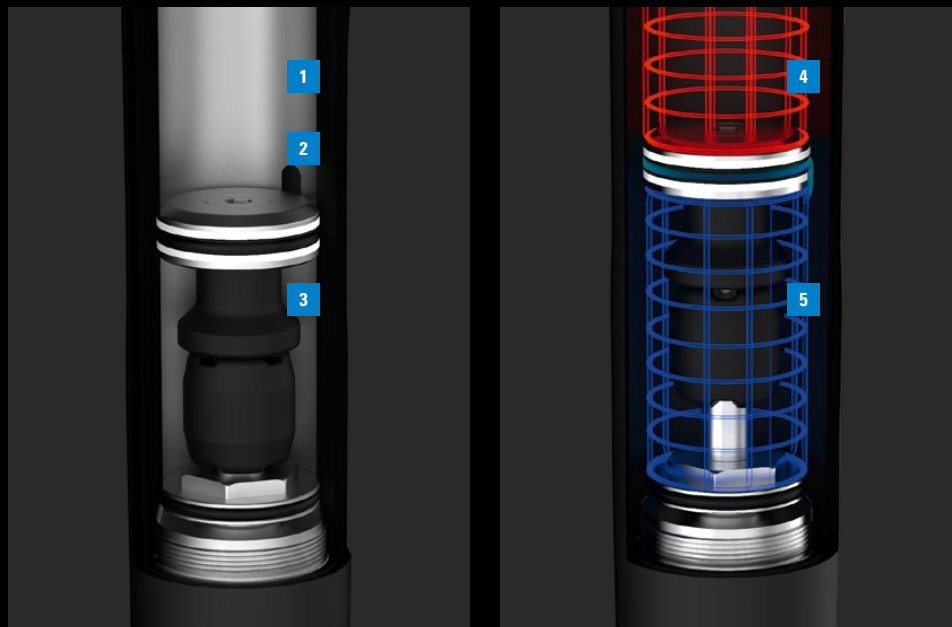

SET YOUR SAG AND THE EQUALIZER (EQ) AIR NEGATIVE SPRING SYSTEM WILL BALANCE IT FOR YOU.

Our tradition of product evolution brings our forks into a brand new era with our all-new air EQ system. The EQ system perfectly equalizes the rider's weight to the spring curve which results in the exact positioning and support you need. This results in a customized feel for each individual rider optimizing sag and volume control. Pairing the EQ system with the external damping adjustments of our PCS cartridges results in a supple coil spring feel in a lightweight, progressive and easy to adjust air spring package. You can set your sag according to your intended riding style and the EQ system will automatically balance it

with the right amount of negative spring force helping you to create a precise and effortless tune. The EQ system will improve fork sensitivity of small repetitive bumps while providing plenty of mid-stroke support for those bigger hits resulting in enhanced comfort and performance when riding any kind of terrain.

FUNCTIONAL FEATURES

- Greater, automatic spring adjustability based on the riding style and weight of the rider
- Improved fork sensitivity for those small but fast repetitive bumps
- Super consistent damping performance in tandem with the PCS system

HIGH & LOW SPEED
COMPRESSION

PCS-PISTON
COMPENSATOR
SYSTEM

38mm A7000
SERIES TRIPLE
BUTTED

HOLLOW
CROWN

HIGH & LOW
SPEED REBOUND

20X110 BOOST
STANDARD

150LC2T110
AXLE

OFFSET
50mm





RUX EVOLUTION OF BIG MOUNTAIN

The evolution of the RUX continues to be a wild and exciting ride. Today's RUX is bred from the many years of collaboration between our riders across the globe and the SR SUNTOUR team, leading to the development of a world class Downhill and Freeride suspension fork. Tried and true, the RUX's list of accomplishments grows longer into 2020, with a consistent presence on World Cup Downhill and Red Bull Rampage podiums. Creating the most reliable, durable, and serviceable suspension on the mountain is what drives the evolution of the RUX. For riders seeking the biggest of big mountain lines, the progression of Freeride, or pushing the fastest time down the track, it is essential to ride with the confidence of an extra stiff 38mm stanchion chassis and fully-sealed R2C2 and RC2-PCS dampers. Whether it's at the home tracks, traveling on a race circuit, hunting down new zones, or just going new places to ride, the ease of performing basic service and maintenance is a pillar of the QSP philosophy that enables riders and mechanics to confidently keep their forks dialed and ready for the next adventure.

MODEL	RUX38 BOOST
INTENDED USE	DOWNHILL
TRAVEL	200mm
WHEEL SIZES	27.5"
SPRING	AIR
CARTRIDGE	R2C2-PCS, RC2-PCS
AXLE TYPE	20mm TOOL TYPE / 20mm TOOL FREE
WEIGHT	STARTING FROM 2845g



E-BIKE
READY

BOOST



PISTON
COMPENSATOR
SYSTEM



LA MINE

***WELCOME
NEW TO THE
MINE.***



THE NOISES GET LOUDER WITH EACH STEP TOWARDS THE MINE. EVENTUALLY, YOU RECOGNIZE THE SOUNDS OF PICKAXES, SHOVELS, AND THE WORKERS' BANTER. AT THE BEGINNING OF THE 20TH CENTURY, UP TO 390,000 TONS OF ANTHRACITE WERE BEING EXTRACTED FROM THIS MINE. THE VOICES NO LONGER BELONG TO THOSE IN SEARCH OF THE CARBON RICH ROCK, RATHER CARBON-NEUTRAL THRILL SEEKERS, SHAPING AND SHIFTING THE EARTH INTO JUMPS.

WORDS RÉMY VROONEN ANALOG AND DIGITAL PHOTOGRAPHY HOSHI YOSHIDA

A mountain biker is captured in mid-air, performing a Superman seat grab. The rider is wearing a black helmet with orange and red accents, a black t-shirt, grey pants, and black gloves. The bike is a white and orange full-suspension mountain bike. The rider's legs are extended horizontally, and the seat is resting on the handlebars. The background is a blurred natural setting with green foliage and brown earth.

**"LA MINE" IS THE PERFECT
PLAYGROUND TO TRAIN WORLD
CLASS SLOPESTYLE SKILLS**

Nico Terrier is showing a Superman
Seatgrab Indian Air stretched to the max.



Welcome to the Mine, a concept developed by Anthony Rocci Louis Reboul and Nicolas Terrier.

When the three lads were all living within a few kilometers of the mine, they all had the same thought; riding the mine could be a perfect blend of freeride and slopestyle. Inspired by the Fest Series, and over an initial, back braking three weeks, they dug around and reshaped the disused mine. Since then, the terrain has been forever evolving, following the contours and lines of their imaginations. At first glance the lines look tangled and jumbled, but as soon as the three riders drop into coordination, the effect is symphonic. Dynamic scrub-shots mixed in with spectacular airtime, create an intensity which builds inevitably to a crescendo on the final big jump.



TOP Louis Reboul and his buddies have access to excavators. Very handy when you want to put new ideas into action. **RIGHT** Louis Reboul is a former Rampage athlete and still one of the best freeriders of the world.





TOP Anthony Rocci is also a Whip-Off champion.
LEFT Kevin's Race support truck stopped by and provided a special tuning service for the slope style athletes.



"La Mine" used to be a mine, hence there is a lot of earth to move around and to play with.

AND ALL THAT NOISE? AS LOUIS SAID "HEY, IT'S CRAZY HERE, WE HEAR NOTHING OTHER THAN OUR OWN SHOUTING AND LAUGHING, ALL THE TIME!"

Louis Reboul. THIS is a superman seatgrab, period.







TOP Louis' and Nicos shared house with a big backyard, trails, miniramp and a magnificent view. **DOWN** Watching the slomo footage on Remys camera: Louis Reboul, Anthony Rocci and Nico Terrier.

AT FIRST GLANCE THE LINES LOOK TANGLED AND JUMBLED, BUT AS SOON AS THE THREE RIDERS DROP INTO COORDINATION, THE EFFECT IS SYMPHONIC.



A unique feature of La Mine is the possibility to synchronise the choreography with up to three athletes on the final jump.



WATCH THE VIDEO!

HIGH & LOW SPEED
COMPRESSION

PCS-PISTON
COMPENSATOR
SYSTEM

38mm A7000
STANCHIONS

HOLLOW CROWN

EQUALIZER
SYSTEM

OFFSET 44mm

20X110 BOOST

20LH-110 AXLE



DUROLUX 38 EXTRA ROWDY

We've taken everything you love about the DUROLUX and made it bigger and badder! The new DUROLUX38 is ready to take on even the most hectic lines with 38mm stanchions for added stiffness and even more precision. The DUROLUX38 is the choice for freeride, gravity riding and the most demanding enduro courses and can handle anything you can throw at it. Whether you're competing against the clock or against the terrain the DUROLUX38 will instill all the confidence needed to get you safely and smoothly down the trail and with our legendary durability you can turn around and do it again and again! Designed tough and smart with A7000 stanchions and hollow forged crown, QSP ports, an integrated fender, fully sealed and serviceable R2C2 and RC2 PCS dampers and extra volume spacers included for easy spring curve adjustment. There is also an ABS version available including Bosch's ABS specific mount and wheel speed sensor mount (WSS). Our tradition of product evolution brings the DUROLUX into a new era with the Air EQ system, perfectly equalizing the rider's weight to the spring curve resulting in exact positioning and support.

MODEL	DUROLUX38 BOOST EQ
INTENDED USE	FREERIDE, ENDURO
TRAVEL	160, 170, 180mm
WHEEL SIZES	29"
SPRING	AIR EQ
CARTRIDGE	EQ R2C2-PCS, EQ RC2-PCS
AXLE TYPE	20LH-110
WEIGHT	STARTING FROM 2500g

DETACHABLE INTEGRATED SHORT FENDER

QSP QUICK SERVICE PORTS

ABS MOUNT VERSION AVAILABLE

FENDER MOUNT

HIGH & LOW SPEED REBOUND

FREERIDE / ENDURO

DUROLUX

// 21/22

SR SUNTOUR

TRIAIR



8 CLICK REBOUND

EASY VOLUME SPACER ADJUSTMENT



3CR 3 MODE COMPRESSION

IFP INTERNAL FLOATING PISTON



TRIAIR2

ESTABLISH TRACTION

Split second reactions to rapidly approaching terrain must be translated smoothly through the bike for the rider to have genuine control. The TRIAIR2 was designed to handle the abuse of long, challenging descents while maintaining consistent damping, holding a steady line. The TRIAIR2 has a redesigned piggyback to allow for better oil flow and clearance with more bikes. Also features an air-backed IFP, riders can adjust this as well as easy volume spacer adjustment to dial in the desired spring curve. The 3CR damping allows for 3 position compression adjustment and 8-clicks of rebound range to create the proper balance between fork and shock. TRIAIR2 is OSP designed for reliability and serviceability, and is the perfect match for the DUROLUX, AURON, and AION forks.

MODEL	TRIAIR2
INTENDED USE	DOWNHILL, FREERIDE, ENDURO, TRAIL
COMPRESSION	3CR, 2CR, R
REBOUND	8 CLICKS
SPRING	AIR (AIR VOLUME SPACER, IFP SYSTEM)
TRAVEL	METRIC: 210x50/55, 230x60/65, 250x70/75 TRUNNION: 185x50/55, 205x60/65, 225x70/75





MEGA VALANCHE



**CELEBRATING THE
25TH ANNIVERSARY**

WORDS JACK READING PHOTO HOSHI YOSHIDA



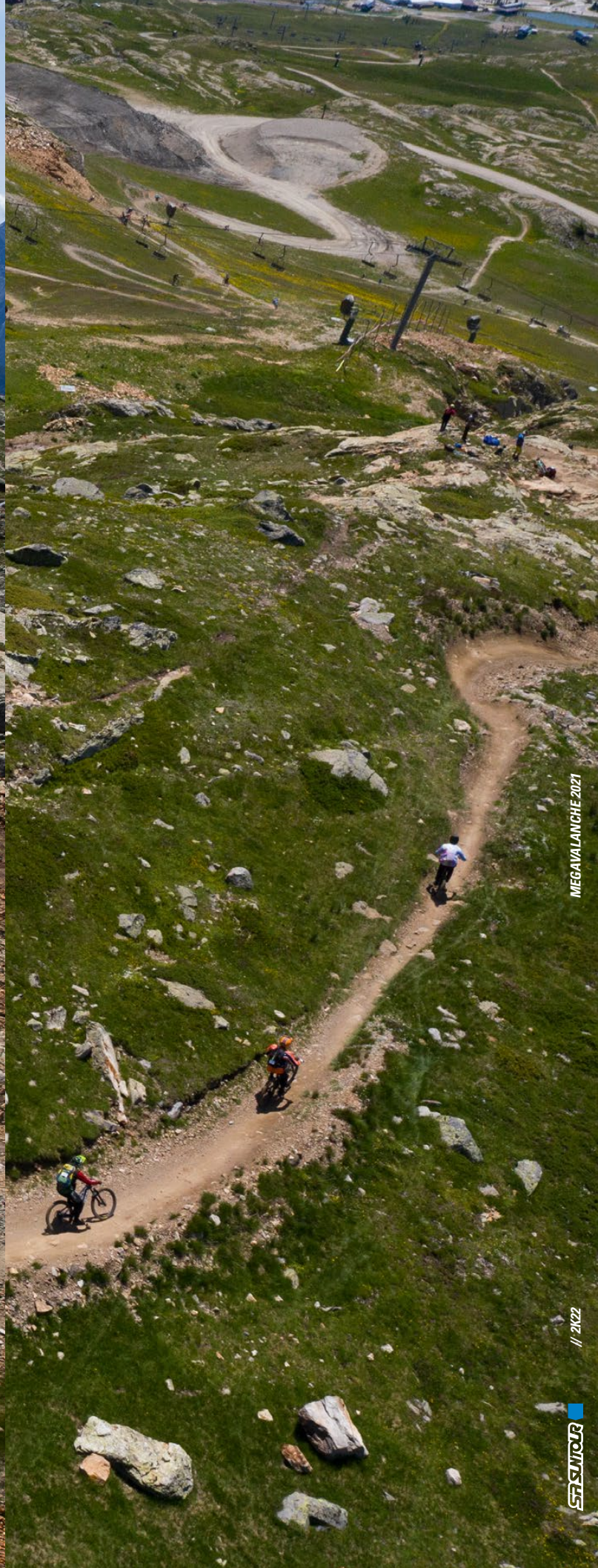
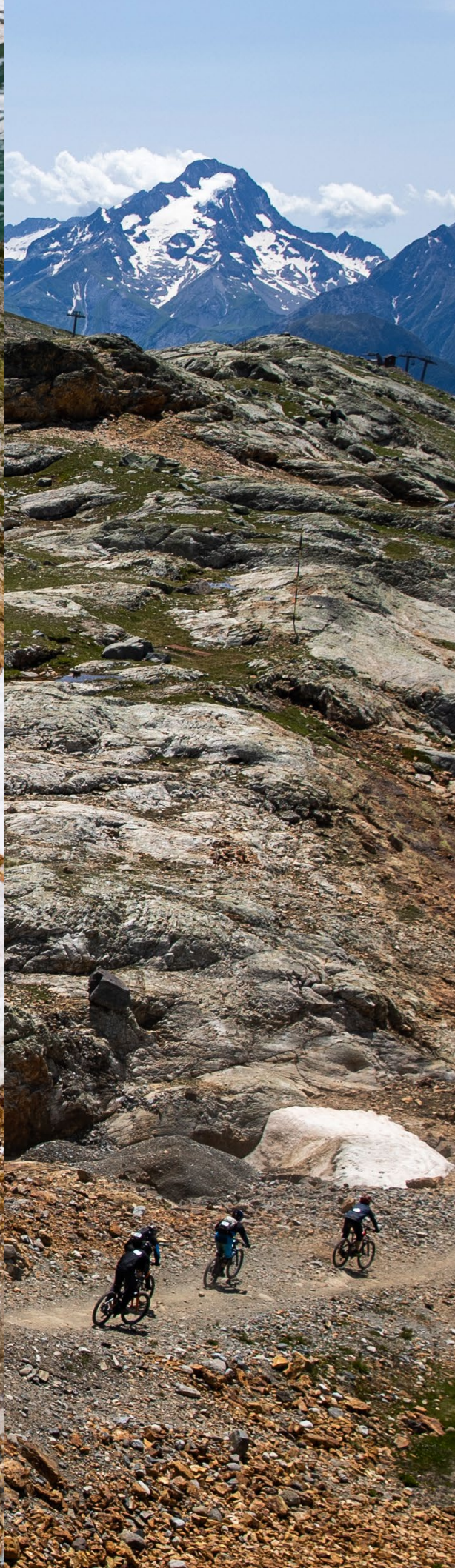

MEGAVALANCHE 2021

// 2022

STANTOUR



»THE UNKNOWN ELEMENT OF STARTING ON THE SNOW WITH A HUGE GROUP OF RIDERS, IS BOTH EXCITING AND TERRIFYING...«

Mick Hannah is racing down the glacier at full speed. Fast riders reach more than 90km/h on the glacier piste. "Sick Mick" is for sure one of them.



The Megavalanche is one of the most infamous mountain bike events in the world. Racing a MTB down a glacier, to any “normal” person that’s just crazy, right? No no, not to the 100’s of riders who line up at the top of the Alpe D’Huez glacier every year for one of the biggest MTB adrenaline rushes you can get. To them it’s one sweet natural high. Most of the riders, who have raced the Megavalanche over the years, will agree that once you’ve made the decision to enter the race for the first time, you instantly feel nervous. The unknown element of starting on the snow with a huge group of riders, is both exciting and terrifying.

The event format, for those not entirely sure, is a mass start from the glaciated summit of Pic Blanc, high above the village of Alpe D’Huez, all the way down to the village of Allemond in the valley bottom. The course drops 2600 vertical meters (8530 feet) and is 20 km long (12 miles). Riders are lined up based on their results in the qualifying race the day before, fastest riders on the front row, working back to the slowest riders at the back. This means a good start and being fast on the snow is critical for a good result, otherwise you’ll end up being stuck in a queue on the single track with limited passing places. This year is the 25th anniversary

of the Megavalanche, and that is so impressive thinking back to the bikes that must have been ridden down that glacier in the late 90’s. There are usually between 1000 and 2000 riders that start the race, but because of Covid-19 restriction in 2021, the event saw 700 manage to make the start line.

The amazing Alpe D’Huez mountains are the setting for the Megavalanche, and are one of the most breathtakingly beautiful places in the world. The town itself sits at an altitude of 1250m and the peak rises to 3330m where the race starts, providing some of the most beautiful terrain to race mountain bikes. The high altitude means the air is very thin, adding another challenge for the athletes competing in the event. The race track isn’t just downhill, it throws in a long flat section followed by a 3 minute climb at the mid way point. The lower oxygen level in the air means riders have to be extremely fit if they hope to be competitive in the race.

This year SR Suntour had some very exciting Werx athletes in attendance. From the downhill side, Mick “Sick Mick” Hannah of NS UR team along with Jack Reading and Dan Slack of SR Suntour Commencal Racing were ready to have a go at the Megavalanche for the first time. Actually that’s not entirely true. In 2007 Sick Mick attended the race, but was involved in a crash in the first turn which destroyed his wheel and took him out of the race. This time he was hoping to make it a bit further down the course.



TOP It is said to be the hardest MTB mass start race in the world. **MIDDLE** Quentin Richard is part of the organising team and in charge for the best spot for our logo branding. **LEFT** World Cup DH rider Jack Reading qualifies in the first row of the finals called the A-Line.



From the enduro world, Torben Drach, Liam Moynihan, Nico Quéré and Premek Tejchman were excited to get racing. Also at the event was David Hovarth, who crashed badly at the Val di Sole downhill world cup in 2019 and since that accident hasn't been able to walk. He rides a recumbent bike fitted out with SR Suntour suspension and was hoping to be the first rider on this kind of MTB to compete in the Megavalanche. Unfortunately David experienced a problem with the motor powering the bike, which means he will have to wait until 2022 to attack the course.

Practice on the glacier was a mad experience for everyone. Before the race the whole glacier is groomed and graded like it would be during a ski season, but they don't do this for the practice sessions, so the snow is very soft and there are lots of ruts and holes. This makes it almost impossible to ride. So the athletes and the media guys had a very entertaining session up there for practice, with lots of legs being thrown around, people riding sitting on their back tyres, and of course lots of crashes.

The course itself is a beast. Glacier to start, and some riders hit up to 70mph up here. It then moves to a rocky single track for about 6 minutes, which has great flow and next to no climbing. There are very few passing places on this section, which can be frustrating if you've had a bad start on the glacier and are stuck behind slower riders. Then it gradually starts to see more and more climbs and flat sections spacing out the sections of single track.

After about 15 minutes, a long flat section starts as riders traverse around the hill just above the Alpe D'Huez village. This finishes with a 3 minute climb to get over to the top of the slope that drops you down into Allemond. From here the riders can enjoy 15 to 20 minutes of wooded single track, spaced apart by short punchy climbs and flat fire road sections. There are lots of passing places in the woods which can make for exciting racing for both riders and spectators. The whole course takes a little over 40 minutes for the best, and is over an hour for the average rider.



TOP Dan Slack practicing the qualification course. **MIDDLE** A little photo session at the end of the practice day with "Sik Mick" Hannah.

THE AMAZING ALPE D'HUEZ MOUNTAINS ARE THE SETTING FOR THE MEGAVALANCHE, AND ARE ONE OF THE MOST BREATHTAKINGLY BEAUTIFUL PLACES IN THE WORLD.





The qualifying race on Saturday is very important, because the better your result, the closer to the front you start on the glacier. This is also a mass start, and in 2021 to guarantee a front row starting position you needed to finish in the top 5 in your qualifying heat. Our Werx athletes had a great day out. Dan Slack was in heat 1 and won his heat. Jack and Liam were together in heat 4 and finished 1st and 2nd respectively. Sick Mick and Torben were also successful, finishing 2nd and 1st respectively in heat 6, with Torben taking the fastest time of the day in qualifying of 14

TOP Nico Quéré is always a contender for the win. **LEFT** Dan Slack from the SR SUNTOUR Commencal Racing Team. He wins his qualification heat. **RIGHT** Matthias Hafner and his teammate Torben Drach who rode the fastest qualification time.





LEFT Mick Hannah is back on the Pic Blanc glacier. After a crash in his last Megavalanche race 2007 it's time to take revenge. **DOWN** Nico Quérés famous dance move is not just a warm up for him.



DOWN The A-startline is filling up from left to right: Torben Drach, Liam Moynihan, Dan Slack and Jack Reading.



minutes 8 seconds, just ahead of Jack and Dan. Nico and Premek also finished top 5 in their heats, which meant all 7 of our Werx riders were set to start front row in the main race.

The start of the Megavalanche is simply electrifying. At 6.30am you climb into the gondola and leave the bottom. You arrive at the top with the sun and get the most amazing view of the surrounding mountain ranges. You feel like you can reach out and touch the Les Deux Alpe Glacier on the opposite side of the valley. Of course it's very cold, but there is enough going on to distract you from this. Riders are invited, in qualifying order, to go and line up their bikes at the start, fastest qualifier first, all the way down to the rider with the slowest qualifying time at the rear. The organisers aim to start the race at 9am, but they can delay things

slightly to wait for the ice to melt on the glacier piste, and give riders the best possible conditions. Next the helicopter appears, and starts circling around the summit over the riders' heads, and music starts blasting from the sound system. This exhilarating atmosphere is perfect for the occasion. Jack Reading described the build up, and the start of the race as one of the most intense MTB experiences he's had in his career. Staring over the edge of the glacier, knowing he had to charge off the start as fast as he could and keep pedalling as the slope dropped away in front of him, in a mad rush to be first man out of the first corner. The riders are given 30 seconds, then a board that says 10 seconds, and anytime after this the board can be pulled away, the tape pulled up, and away they go.





TOP This is the A-Startline for the finals. And seven SR SUNTOUR athletes made it onto the pole position. **RIGHT** Interview time with Jack Reading.



»2021 WAS AN AMAZING MEGAVALANCHE. WITH TWO SR SUNTOUR RIDERS ON THE PODIUM IT WAS A SUCCESSFUL RACE FOR US, WELL DONE JACK AND TORBEN...«

As soon as that tape goes up it's a daring battle of who can pedal the hardest and brake the latest into the first corner. It's so important to get a good start, and for Jack and Mick it was just that. Jack's plan worked and he made it to the first corner in the lead and was out front for most of the glacier. He lost the lead at the end of the snow, getting a line wrong into a fast corner before a flat section. A consequence of it being his first time riding the glacier at full speed. Jack left the glacier in 2nd place and managed to have a good race finishing in 4th place. You can watch his race run over on his YouTube channel.

Sick Mick came off the glacier in 3rd and after a great battle with Dan finished in 16th place. Dan, Torben and Liam didn't have a good start and all came off the glacier in bad positions after being involved in pile-ups. Dan worked his way back from around 50th place when he left the glacier into an impressive

15th. Liam also had a mechanical problem, and then rode hard to an impressive 9th place. Torben used his enduro fitness to work his way through the riders after the glacier, and was only 10 seconds behind Jack in 5th after the climb. He and Jack then battled all the way to the finish with Torben crossing the line in 5th place. Nico had a mechanical problem and finished in 31st place.

2021 was an amazing Megavalanche. With two SR Suntour riders on the podium it was a successful race for us, well done Jack and Torben, who managed this at their first attempt at the race. Both athletes are excited to improve on this in 2022 now they have some experience. It really is a fantastic event, and we highly recommend it all serious mountain bikers, so make sure you add it to your bucket list, and head to Alpe D'Huez to experience it for yourself!

LEFT Mick Hannah was leading the qualification but Torben Drach passed him on the final pedal section. Two A-startliners though for SRSUNTOUR. **MIDDLE** Abby Hogie was the only lady in our team. We need more ladies at the Mega, where are you?

HIGH & LOW SPEED
COMPRESSION

PCS-PISTON
COMPENSATOR
SYSTEM

35mm A7000
SERIES TRIPLE
BUTTED

EQUALIZER
SYSTEM

OFFSET
51/44mm (29")
51mm (27.5")

15X110 BOOST
STANDARD

150LC2T1110
AXLE





AURON TRAIL DETAIL

The AURON is back with the added strength of a 35mm stanchion chassis and the attitude of a well rounded trail fork. This is versatility expanded to longer climbs for never ending descents and everyday trail riding. The 160mm maximum travel is oriented for wide range of all-mountain trail bikes, offering 27.5" and 29" and a variety of PCS cartridge options available. QSP design means that changing the travel between desired lengths is simple via snap-on internal spacers. The new Air EQ system, perfectly equalizes the rider's weight to the spring curve resulting in exact positioning and support. The Air EQ system creates a customized feel for each rider, optimizing proper sag and volume control in conjunction with the external damping adjustments of our sealed RC2 PCS damper cartridges. The result is a supple coil-spring feel in a lightweight, progressive and easy to adjust air-spring package. The AURON lives up to a high standard of durability, while designed for more nimble trail riding than its bigger siblings.

MODEL	AURON35 BOOST EQ
INTENDED USE	ENDURO, TRAIL
TRAVEL	130, 140, 150, 160mm
WHEEL SIZES	29", 27.5"
SPRING	AIR EQ
CARTRIDGE	EQ RC2-PCS, EQ RLRC-PCS, EQ LORC-PCS
AXLE TYPE	15QLC2TI-110
WEIGHT	STARTING FROM 2100g

29 27.5 35mm BOOST PCS PISTON COMPENSATOR SYSTEM EQ^{lth} EQUALIZER



DETACHABLE
INTEGRATED
SHORT FENDER

FENDER MOUNT

LOW SPEED
REBOUND

ZEROON

LOW SPEED
COMPRESSION

35mm A6000
SERIES BUTTED



OFFSET 51mm

15X110 BOOST
STANDARD

15QLC32-110
AXLE





ZERON

RIDE MORE, SPEND LESS

The new ZERON35 AIR is one of the highest value performance forks on the market. The ZERON can handle all the speed, long climbs and technical terrain you can throw at it with a sturdy chassis featuring forged crowns, A6000 series 35mm alloy stanchions and a high-performance sealed cartridge. The air spring and adjustable cartridge means you can dial in your ride to fit your weight, riding style and terrain. Consider it also follows our QSP design philosophy for ease of service and basic maintenance, and it's budget friendly price and it becomes clear that the ZERON is an industry leader in value, performance and ease of use. Available in 27.5" and 29" sizes and e-bike ready means it's ready for just about anything.



DETACHABLE
INTEGRATED
SHORT FENDER



ZERON

FENDER MOUNT

POST MOUNT
180 DIRECT

LOW SPEED
REBOUND

MODEL	ZERON35 BOOST AIR & COIL
INTENDED USE	ENDURO, TRAIL
TRAVEL	130, 140, 150, 160mm
WHEEL SIZES	29", 27.5"
SPRING	AIR
CARTRIDGE	RC, RLR, LOR
AXLE TYPE	15QLC32-110
WEIGHT	STARTING FROM 2320g



E-BIKE
READY

BOOST

2CR REMOTE VERSION
AVAILABLE

AIR VOLUME SPACER
ADJUST

LOW SPEED
REBOUND ADJUST

2CR COMPRESSION
WITH FIRM AND
OPEN MODE





EDGE PLUS THE INLINE ANSWER

Whether pinned on the XC race course or ripping around your rowdy local trails, having reliable rear suspension is essential to success as much as it is to enjoyment. The EDGE PLUS can tackle the nasty rock gardens, let you boost jumps on your favorite flow trail, provide endless traction on those loose corners and then give you maximum efficiency back up to the top so you can do it all over again. Available in most popular sizes the EDGE PLUS has a variety of external adjustments including remote and partial lockouts, compression and rebound damping control, and easily adjustable volume spacing so you can tune the feel to match your bike, weight and riding style.

MODEL	EDGE PLUS
INTENDED USE	ENDURO, TRAIL, CROSS COUNTRY
COMPRESSION	2CR, R-2CR (REMOTE VERSION), RC, R
REBOUND	8 CLICKS
SPRING	AIR
TRAVEL	INCH: 152x31mm, 165x38mm, 184x44 mm, 190x51mm, 200x51/57mm METRIC: 170x30/35mm, 190x40/45mm, 210x50/55mm, TRUNNION: 145x30/35mm, 165x40/45mm, 185x50/55mm
WEIGHT	300g (165x45mm)



PODIUM RUSH



TOM PIDCOCK: 5TH, 2ND, 1ST, GOLD.

WORDS COLIN MEAGHER
PHOTO HOSHI YOSHIDA (ALBSTADT),
ANDY VATHIS (NOVE MESTO),
SWPICS (TOKYO OLYMPICS)







»I WAS BORN TO RIDE A MOUNTAIN BIKE. IT SOUNDS STUPID, BUT IT'S WHAT I HAVE DONE SINCE I WAS LITTLE AND WHAT I'VE ENJOYED THE MOST.«



SR SUNTOURS collaboration with Tom Pidcock and the Ineos Grenadiers team began in early 2021.

Thomas Pidcock is that once in a cycling generation phenom. He's young—only 21—and at 171cm and 58 kg, he's not particularly imposing. But make no mistake: that unassuming figure has become legend. He's proven himself at road and cyclo cross on the world stage with bronze in the 2019 U23 road cycling world champs and silver in the 2020 cyclo-cross world champs but in his own words following his Nove Mesto 2021 win, "I was born to ride a mountain bike. It sounds stupid, but it's what I have done since I was little and what I've enjoyed the most."

ALBSTADT 2021

With no elite top 40 UCI World Cup ranking, Pidcock was unable to participate in the Short Track Cross Country event the Friday before the main event and thus relegated to an 11th row start in this, the first World Cup XC race of the 2021 season. With Albstadt's mix of brutal climbs, single track, and steep descents, the handicap of that back row start meant that merely getting into the top ten, let alone to the podium, promised to be a battle—the young British rider would need to overtake 80 riders to get to the front. To say Pidcock had his work cut out for him would be an understatement, but the Brit was upbeat, stating, "It's a different game when you get to elite. It's nice to come in with the confidence of a win in my first big race (a Swiss Cup XC race in Leukerbad the week prior to Albstadt), but having a back row start...it can only get better from here."

And from the start, Pidcock rose to the challenge, moving up to 25th position by the end of the start loop.

Aggressive passing continued to be his strategy—he certainly wasn't making any friends in the early laps, as the track is tight in places, but Pidcock came to win, not to make friends.

Chipping away at the leaders saw Pidcock inside the top 20 halfway through lap one. Then 13th. Then inside the top ten at the beginning of lap two. He would get within the top five by the end of that lap, dangling some two seconds off the front. So close! Lap three saw the catch, with the British phenom briefly take the lead; but he quickly surrendered that to the Swiss boss, Nino Schurter, on the first climb. But simply burned too many matches with his madcap battle to gain the front. Soon he ceded another position, then another. By the start of lap five he'd slipped just outside of the top five, some 16 seconds off the front. He never relented, ultimately coming home fifth, 29 seconds off the winning pace set by Victor Koretzky, and with only Schurter, Mathias Fluekiger, and Ondrej Cink ahead of him. Not at all a shabby finish for one's first Elite World Cup XC race, never mind the handicap of starting in the back.

LEFT Tom catches up with the leading group after just 2 laps, and actually took over the lead. A flat tire briefly holds him up, but in the final sprint he secures 5th place and with it, his first podium in his first elite year.

RIGHT Meticulous maintenance after each training session by SR SUNTOURS chief mechanic Kevin Allemmand.





LEFT Thanks to his 5th place in Albstadt, Tom is qualified for the XCC Short Track Race. With his 2nd place he secures a spot on the first row for the Elite XCO race.



TOP After the 3rd lap, Tom unleashes his attack and opens a gap of over 1 minute to his pursuer Mathieu Van der Poel and takes a sovereign victory after six laps. **RIGHT** Loves mud: The medal winning AXON34 WERX suspension fork was already crowned with a World Champion title in 2020.

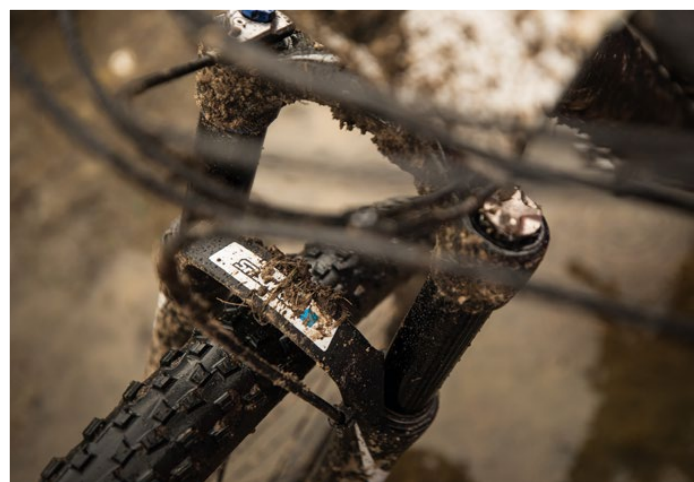



WITH THIS VICTORY IN ONLY HIS 2ND ELITE WORLD CUP RACE, HE SECURES A STARTING PLACE AT OLYMPIA IN TOKYO 2021.

NOVE MESTO 2021

Coming only a week after the German race, the Czech Republic UCI World Cup Cross Country racing classic couldn't be more of a contrast: yes, steep climbs, but rather than the fairly non-technical track of Albstadt, Nove Mesto demands technical handling skills, both for climbing and descending. Additionally, the rain came, dropping the temps from Albstadt's smoldering 29°C to 15°C, and making an already challenging track slippery as well as technically challenging.

But if past history is any indication, Pidcock has those handling skills, having won both U-23 races of the Covid-19 impacted 2020 World Cup event at this venue, and CX racing at any level means coming to terms with slick conditions. And he had exactly the right tool for the job, swapping his unbranded Axon34 WERX EQ equipped hard tail from Germany for a similarly equipped unbranded BMC 4 Stroke full suspension bike, which offered 100mm of EDGE rear damped travel for the roots and rocks of the Czech woods. And this time, too, the Brit was able to take part in the short track race prior to the main event, where his finish just behind that short track winner and fellow phenom Matthieu Van Der Poel ensured a front row start in the big dance.

From the gun, great things were expected, and from that start the Grenadiers rider delivered. But not without a battle first: Van Der Poel, the big Dutch rider lined up next to the young Brit blew everyone's doors off in 2019 at this venue, and his win over the Grenadiers rider in the short track showed that he, too, had come to dominate.

Initially, it was Van Der Poel setting the pace, with a confident Pidcock sitting in fourth—a tactical move to assess pace and strategize without losing contact. VDP is known to push the pace at the start in order to devastate the competition, relying on his ability to recover to overpower his rivals. But Pidcock was right on the Dutch rider's wheel by split one of the first lap, followed by the "local" rider, Czech Ondrej Cink.

But it quickly became evident that—barring any sort of a mechanical mishap—it was going to be either Pidcock or VDP for the win, never mind Cink's home ground advantage. The two phenoms shredded the field in the start lap before beginning a game of cat and mouse. And what a game! Where others were forced off their bikes to run some of the slick climbs, these two rode. And on the descents, both kept it upright despite the slippery roots liberally spiced with rocks. On lap three, Pidcock made his move, blasting up a steep climb with a viscous attack that opened up a 30-second gap over his rival.

From there it was somewhat uneventful, as the young Brit continued to apply pressure, never relenting, and most definitely never looking back! If he had, he would have seen Swiss rider Mathias Flueckiger briefly challenging VDP in the fourth lap before settling in the third position. But for Pidcock it was a commanding win as he came home after six laps to claim the win a full minute over Van Der Poel, with Flueckiger, Ondrej Cink, and Jordan Sarrou rounding out the podium.



RIGHT Tom followed by Switzerland's multiple world champion Nino Schurter and his team mate Mathias Flueckiger in a technical rock section.



Triumph! Tom Pidcock of Great Britain wins the men's cross-country race and is the youngest crowned Olympic Mountain Bike Gold Medalist at the age of 21.

»IT'S PRETTY CRAZY THAT I BECAME AN OLYMPIAN, WHEN I WAS TRYING TO TELL MYSELF AT THE START OF THE RACE THAT IT'S SPECIAL JUST TO BE HERE.«

OLYMPIC GAMES 2021, TOKYO

A bonus of these stand out performances was Pidcock securing the only Olympic slot for a male British rider. From there it was meant to be a break from MTB racing until the Les Gets World Cup to mix in a bit of road racing with the Tour of Suisse. But then disaster struck: on the last day of May, Pidcock broke his collarbone in five places when he was hit by a car during a training ride, requiring surgery to repair. Keep in mind that the Olympic XC race at this point was only 56 days away. To say Pidcock's hopes were dashed would be an understatement. But he focused on recovery: within six days he was back on a bike, albeit a trainer vs. actually riding. And while he toed the line in Les Gets, he wisely DNF'd, focused instead on 'Mission Impossible': getting ready for Tokyo. "It does not feel real, really"

The Tokyo Olympic Games. The track in Izu is relentless. It's a gorgeously sculpted blend of technically challenging terrain liberally spiced with boulder fields, and mixed with vertically challenging, full gas efforts. Basically, there is nowhere to hide, few places to recover, and even fewer places to launch an attack.

Heading into this race the young Brit had lingering doubts: would his collarbone hold up? And he was fit, but with no full races since the training accident, how was his form? But one thing he didn't doubt was SR Suntour's TACT E-suspension, an electronically controlled fork and rear shock that delivers exactly the blend of wide open or fully locked out suspension required, and everything in between, without needing rider inputs. Pidcock was able to test it vs. other platforms and chose this, never mind it's cutting edge design vs. more traditional suspension platforms.

Race day saw the recovering rider in familiar territory: relegated to a fourth row start, an underdog with the odds stacked against him...Albstadt anyone? But if there's one thing the Brit has made clear, he has high expectations of himself and he delivers. The soaring temperatures and high humidity did little to deter

him, either: he'd spent the weeks leading up to this race "heat training" at the end of each workout. He knew he'd done the hard work. He was fit. And while the race temperatures were going to be unpleasant, no one was going to feel good.

And from the gun, Pidcock was on. He blasted through the riders in front of him on the start lap and was within easy striking distance of reigning Olympic champ Nino Schurter and the overall World Cup leader Matthias Flueckiger by the start of the first full lap. For the next two laps he seesawed between fifth and second. Then he pounced.

Again, this is a track that never really lets up. There are some serious rock gardens, and many of the climbs were loose and dusty—any mistake would be costly. Choosing when to attack meant creating an opportunity in unforgiving terrain. This is exactly what Pidcock did early on lap three, and he threw the gauntlet down hard. For the rest of the lap he led out the two Swiss riders, never letting them close. On lap four he pulled up briefly to assess their strength and then instantly went back on the offensive, chaos in his wake as first Schurter, and then Flueckiger tried and failed to keep with him. All the while, Pidcock put on a clinic that far belied his age. He finessed the technical segments, stayed rock solid on the climbs, and hammered every single flat section of track. This masterful riding forced a costly bobble from Flueckiger on lap five, and the determined Pidcock never let the eventual silver medalist back within striking distance.

And so it would end—an improbable Cinderella story: Pidcock taking the gold (the youngest ever to do so, and Britain's first ever Olympic MTB Gold) despite the odds heading into this race, Flueckiger taking Silver, and Spaniard David Serrano taking Bronze. In his own words, "it's pretty crazy that I became an Olympian, when I was trying to tell myself at the start of the race that it's special just to be here." Special indeed.

RLRC REMOTE
LOCK OUT

PCS-PISTON
COMPENSATOR
SYSTEM

34mm A7000
SERIES TRIPLE
BUTTED

ONE-PIECE
HOLLOW
CARBON UPPER

EQUALIZER
SYSTEM

OFFSET 51mm

15X110 BOOST
STANDARD

150LC2T1110
AXLE



AXON BEYOND XC

A staple at the front of the pack, the AXON WERX remains a top contender. QSP in XC race terms means owning the confidence to push through both terrain and physical suffering. The AXON WERX has seen success at the highest levels of competition, finding Olympic and World Cup podiums under some of the most impressive athletes in the world. The demands of XC racing are grueling, to succeed requires precision control and performance consistency. The AXON34 WERX Boost is in a league of its own, having a one-piece hollow carbon upper and 34mm stanchions that maximizes stiffness at a proper race weight. The new Air EQ System is perfectly balancing positive and negative air chamber for exact support and excellent performance for each individual rider and weight. The development of the Air EQ System involved long-term testing with our World Cup XC racers – the result is a QSP worthy full air-spring that gives supple small bump compliance while maintaining proper support for every rider throughout the travel. Ascending to 34mm stanchions, the first seen on the World Cup XC circuit, with carbon crowns, travel up to 120mm, along with the Air EQ System, makes the AXON34 WERX Boost a true leader. This is the evolution of Refined Simplicity.

MODEL	AXON34 WERX BOOST EQ
INTENDED USE	CROSS COUNTRY
TRAVEL	100, 110, 120mm
WHEEL SIZES	29"
SPRING	AIR EQ
CARTRIDGE	EQ RLRC-PCS
AXLE TYPE	15QLC2TI-110
WEIGHT	1598g W/O AXLE & FENDER (AXON34 BOOST WERX 29")



BOOST



PISTON
COMPENSATOR
SYSTEM



EQ III
EQUALIZER

LOW SPEED
REBOUND

HYDRAULIC LOCKOUT
& HYDRAULIC REMOTE
LOCKOUT VERSION

HARD ANODIZED 32mm
STANCHIONS

OFFSET 45.4,
46.2, 47mm

15AH2, 12AH
(OP) AXLE



DETACHABLE
INTEGRATED
SHORT FENDER

FENDER MOUNT

FLAT 160 DIRECT
BRAKE MOUNT

ADJUSTABLE
REBOUND DAMPING



GVX

EXPLORE THE ROAD LESS TRAVELED

Performance is rooted in durability and reliability. Whether you're exploring endless gravel roads, racing on the ever-more technical Cyclocross courses, lining up for a 100 mile gravel race or building a sleek new e-Gravel bike, the GVX suspension gravel fork from SR SUNTOUR is for the gravel experience. Suspending you on 32mm stanchions with travel and damping adjustments create traction, comfort and versatility that puts the GVX in a class of its own. The versatility designed into the GVX is wide reaching, accommodating a variety of tire sizes, riding styles, and conditions. At the end of an all-day adventure or during the last few miles of that gravel century your body will be thanking you for choosing the GVX.

MODEL	GVX32-S
INTENDED USE	GRAVEL
TRAVEL	40, 50, 60mm
WHEEL SIZES	700C
SPRING	AIR
CARTRIDGE	LOR, RLR
AXLE TYPE	15AH2, 12AH
WEIGHT	1670g (SF21-GVX32-S-FDS-LO-R, W/O AXLE)



E-BIKE
READY

***GET READY
TO GRAVEL***



THE GRAV KARL GRAVEL BIKE PROJECT

WORDS RÉMY VROONEN PHOTO HOSHI YOSHIDA / OUTDOOR PHILIPP JÜLICH

AUGUST 2020, THE WEATHER IS AT ITS BEST AND PEOPLE ARE OUT ENJOYING RIDING THEIR BIKES. AS WE ARE CONSTANTLY EVOLVING IN A FAST-PACED WORLD, NOW FACED WITH A PANDEMIC, WE THOUGHT AN ENJOYABLE WAY TO COME BACK WAS TO HAVE SOME FUN, BUILD A GRAVEL BIKE AND LAUNCH OUR NEW SR SUNTOUR GVX GRAVEL FORK.

GET READY TO GRAVEL

// 2022

SUNTOUR





We decided to take the time to build a “local” gravel bike, so we called Portus Cycles, a steel frame builder from Pforzheim, Germany. As soon as the idea took seed, other partners came on board such as the gear box manufacturer Pinion, Gates for the belts and crankset, Hope for the wheels and stem and Vecnum for a nice, clean dropper post. The whole process took two days, from cutting the tubes to powder coating the frame and getting the bike assembled. This dream build began by drawing the frame on a 3D software design tool using the dimensions you choose, head tube angle, seat tube angle, tyre diameter, BB drop, wheel size and so on... Once the drawing is done, the tube cutting can start.

LEFT Portus handmade frame with Columbus Zona tubeset, Pinion C1.12 with 12-speed transmission, Gates Carbon Drive and the new SR SUNTOUR GVX suspension fork with 40mm travel **DOWN** Alex Clauss is an engineer, a welder and the owner of PORTUS Cycles.



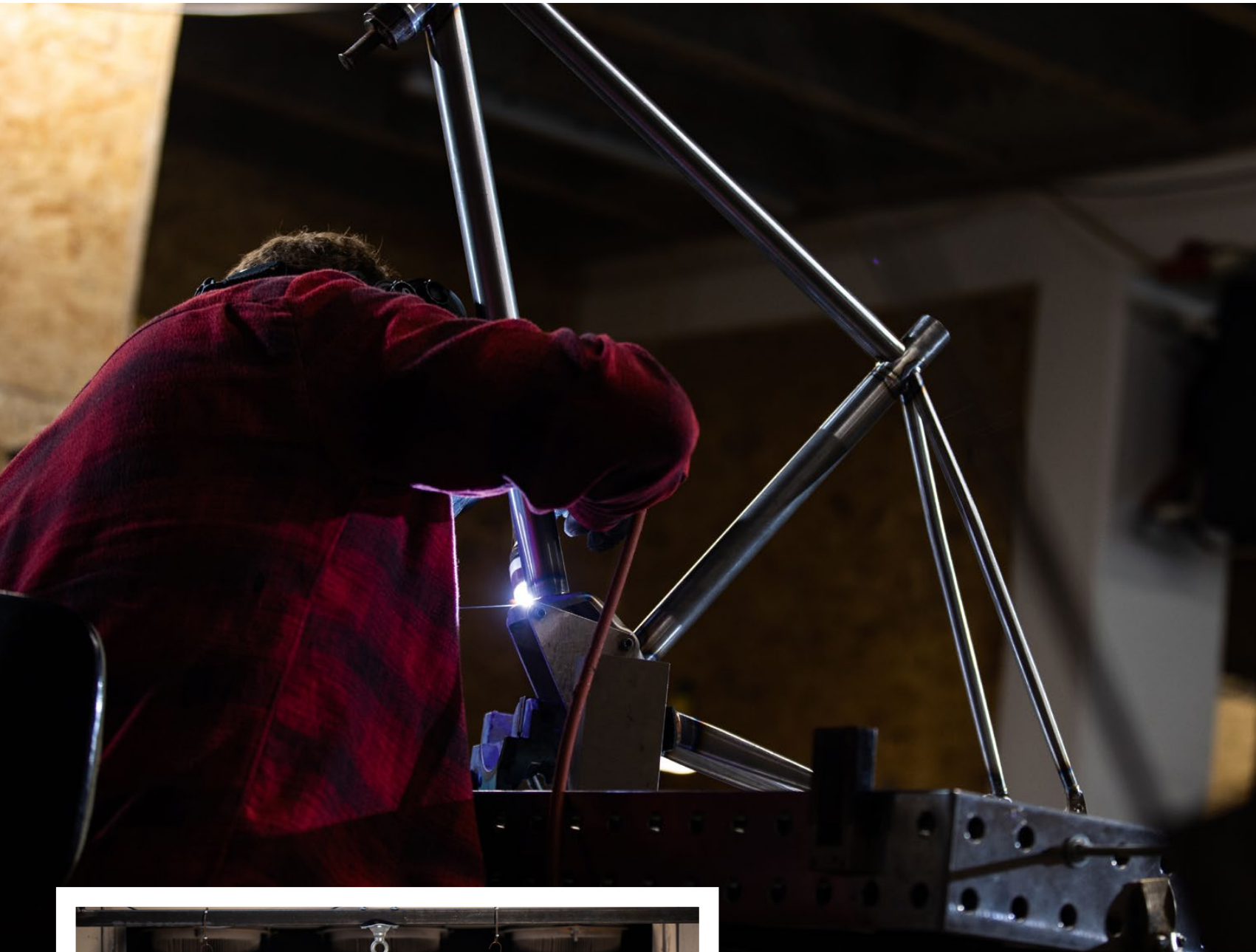

TOP We love welding. We love handmade bikes. **LEFT** Before the frames gets the powder coating the surface needs to be treated by sandblasting and a lavation.

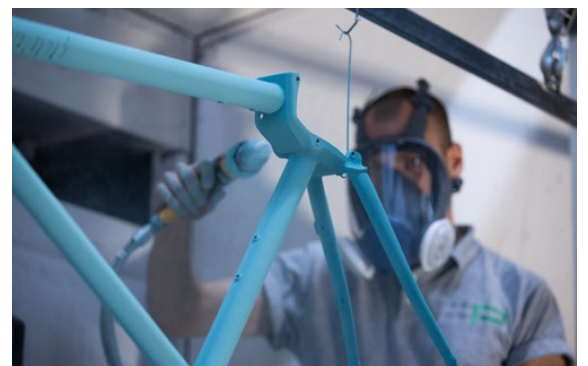



LEFT The magic moment when everything comes together and everything perfectly fits. **DOWN** The Portus Gravelbike turned out to be the perfect adventure and travel bike for all seasons.

WELDING THE JOINTS MAKES THE MAGIC HAPPEN, AS YOU REALIZE A BIKE FRAME IS COMING TO LIFE.

Then jigs are used to tightly fit the mitering, which is called notching in the frame builder's world. As the parts are assembled onto the jig, a first preview appears and shows how the bike looks with the selected angles and the different tubes in place. Once the tubes are correctly aligned, the braze welding process can start. From the bottom bracket to the chain stay, welding the joints makes the magic happen, as you realize a bike frame is coming to life.

The raw frame is now a real thing. It is then taken to the sand blasting unit to get rid of any irregularities and to thoroughly clean it before the final step, the powder coating. Enjoy the building process through our pictures and video and get ready to gravel.



EPISODE 1

WATCH
THE VIDEOS



EPISODE 2



100mm

3CR-PCS / 2CR-PCS
COMPRESSION
ADJUST

PCS-PISTON
COMPENSATOR
SYSTEM

LAMP MOUNT
ON CROWN

AIR SPRING
ADJUST

HARD ANODIZED
35mm STANCHIONS

EQUALIZER
SYSTEM

NEW MOBIE35

OFFSET 44mm

15LH-110
AXLE



DETACHABLE
INTEGRATED
SHORT FENDER

FENDER MOUNT

MOBIE MODERN DESIGN FOR THE E-EXPERIENCE

Combine the comfort and reliability of the NCX family, the stability of a mountain bike fork, and a polished modern design, and you have MOBIE. Nearly every urban setting is seeing a steep rise in bicycling traffic- economical, environmental, and fun, these commutes only get better. The MOBIE is discreetly a powerful eBike rated urban fork. Featured with 32mm (E25), 34mm (E45) and 35mm (new MOBIE35 as shown left) stanchions for control and stability, along with air and coil options. Comes in all the popular urban wheel sizes, including the new 20" version for the newest cargo and mobility bikes. For added performance, we include direct brake mounts and a 15x100mm QLOC axle. Integrated fender and light mounts complete the package as so you can ride in any weather at any time of day. The e-Experience is enhanced mobility.

MODEL	MOBIE45, MOBIE25, MOBIE35, MOBIE34, MOBIE34-CGO-BOOST, MOBIE A32, MOBIE A32-CGO
INTENDED USE	URBAN / UTILITY
TRAVEL	60, 63/75, 70, 80, 100mm, MOBIE35: 120, 130, 140, 150, 160mm
WHEEL SIZES	29", 700C, 27.5", 20"
SPRING	AIR EQ, AIR, COIL
CARTRIDGE	3CR-PCS, 2CR-PCS, 2CR, RLR, LOR, RL, LO, NLO
AXLE TYPE	15QLC32, 15AH2, 15LH-110
WEIGHT	2250g (SF22-MOBIE35 ABS 29") 2150g (SF21-MOBIE34-ABS) STARTING FROM: 1940g (MOBIE 45), 2000g (MOBIE 25), 2160g (MOBIE A32), 2700g (MOBIE A32-CGO)

29" 700C 27.5" 20" |
 35mm 34mm 32mm |
 E-BIKE READY

URBAN / UTILITY

MOBIE

// 2022

SF SULTOUR



LAMP MOUNT

HYDRAULIC LOCKOUT
WITH FIXED REBOUND
DAMPING

32mm STANCHIONS

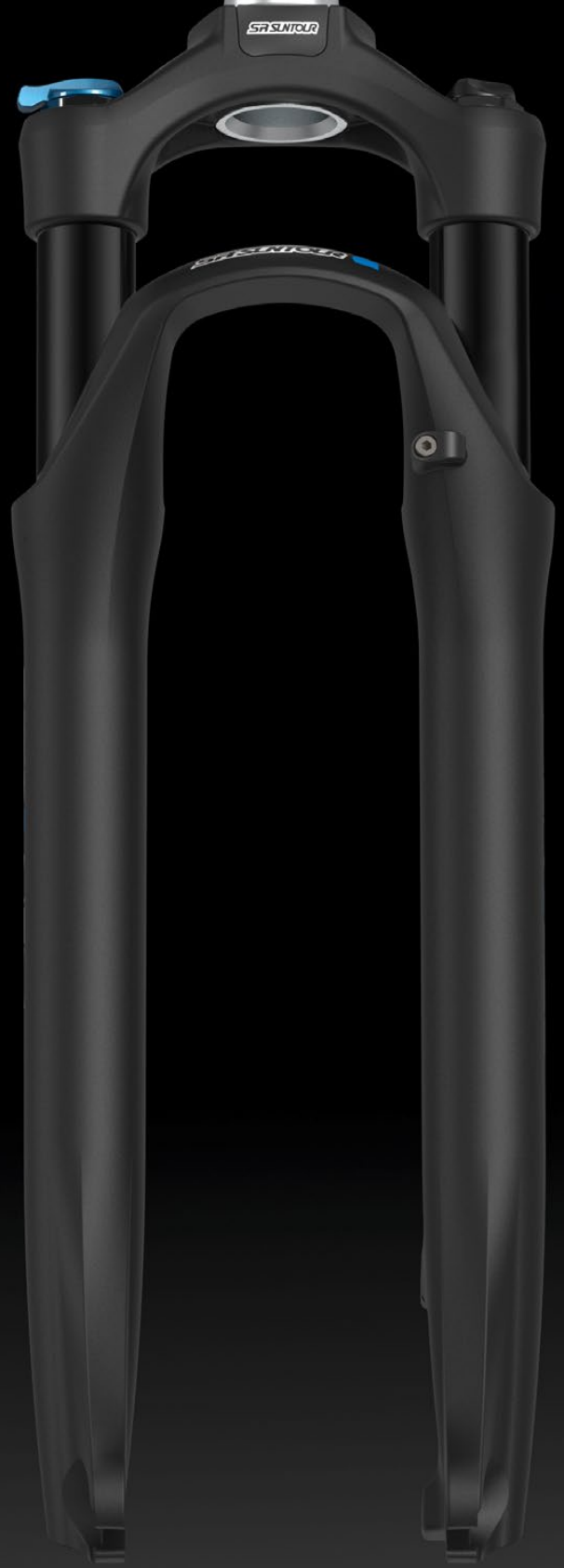

AIR SPRING OR
COIL SPRING
WITH PRELOAD
ADJUST



FENDER MOUNT

NCX32 MODERN TREKKING

Whether riding around the neighborhood or trekking to the next town over, smooth out all the bumps, potholes and bad surfaces with the NCX32. Get all of the comfort and performance you desire in an elegant lightweight, ebike ready package. The NCX features an adjustable spring (air or coil), magnesium lower case and has an easy lockout switch for turning off the suspension when you might not want it.

MODEL	NCX32
INTENDED USE	CROSS / TREKKING
TRAVEL	63/75mm
WHEEL SIZES	29", 27.5"
SPRING	AIR, COIL WITH PRELOAD ADJUSTER
CARTRIDGE	RL, LO
AXLE TYPE	9mm DROPOUT
WEIGHT	2120g (SF21-NCX32-E-DS-LO-AIR 27.5")



COMMUTING



RIDER SIMON DIENER
LOCATION SCHAUINSLAND, BLACK FOREST, GERMANY
PHOTO RÉMY VROONEN

TO YOUR NEXT ADVENTURE



WHAT DOES BIKE COMMUTING MEAN TO YOU? RIDING YOUR BICYCLE TO WORK AND BACK? THAT'S WHAT MANY THINK AND WE THINK THAT'S GREAT BUT THERE'S NO NEED TO LIMIT IT JUST TO THAT.

Commuting to us means using your bike to achieve your goal. Maybe it's getting to work or grabbing a cup of coffee. That's a great way to use your bike. But why not commute to your next adventure? With a variety of bikes and ebikes today you can commute to do almost anything. With modern batteries and suspension you can commute in any season, at anytime of day, to anywhere you can dream. So commute to your next outdoor activity, your campsite, or to your next adventure and SR SUNTOUR can help guide the way.



WATCH THE VIDEO!



SR SUNTOUR E-BIKE SYSTEM

YOUR DRIVING FORCE

Power, Dynamic, Range; the full extent of what is possible for bicycles is ever increasing, evidenced by the advent of pedal-assist.

SR SUNTOUR's history of innovation and forward-thinking is long and well established. Developments within our E-Bike systems push the realms of possibility beyond the known. It is a time of uncharted exploration for bicycles.

The Top Drive freewheel function enables the rider to maintain steady, consistent motion with or without assistance, achieving the accustomed feel of a freehub. The rear-hub motor provides direct power to the rear-wheel, leading to the active feel without compromises in shifting performance.

Our core philosophy of QSP (Quick Service Product) is a significant aspect of the E-bike system. The maintenance in mind design allows dealers, mechanics and riders ease of service and troubleshooting. Synchronizing the utilization of components simplifies both assembly and access, reducing service time, which in turn means more ride-time. The SR SUNTOUR E-Bike System is refined simplicity for the evolving world of E-bikes.



TOP DRIVE TECHNOLOGY

100% freewheel effect in any situation - even beyond electric support.



QUICK SERVICE PRODUCT

Simple construction and service for uninterrupted performance and longevity.



MODEL	R250 HP
AXLE	THREADED AXLE
MAX. TORQUE	60NM
POWER NOMINAL	250W
POWER MAX.	450W
SPEED	7-11 SPEED SHIMANO COMPATIBLE
SYSTEM VOLTAGE	36V DC
WEIGHT	3200g

MODEL	F250 HP
AXLE	THREADED AXLE
MAX. TORQUE	40NM
POWER NOMINAL	250W
POWER MAX.	400W
SYSTEM VOLTAGE	36V DC
WEIGHT	2300g

THE WERX FAMILY

THE SR SUNTOURS WERX PROGRAM, IS BUILT AROUND A PHILOSOPHY OF BUILDING PRODUCTS TO MEET THE DEMANDS OF THE WORLD'S BEST ATHLETES.

The WERX program athletes are cut from as patterned a fabric as possible; from the high octane world of the Olympics to the parallel universe of the Red Bull Rampage. Many strands bind together to form a core of elite athletes and World Class product testers.

Both the R2C2 cartridge with PCS (Piston Compensator System) and the EQ Equalizer air-forks are conceived and born from hard fought competition, relentless testing and state of the art technology. Our DB3 device enables us to measure with extreme accuracy the behaviour between the damper and air-spring through massive hits and rapid-fire impacts. This digital data has been backed up with the undeniable proof of medal-success. Tracey Hannah was crowned 2019 DH World Cup Winner and Jordan Sarrou took his place in history being crowned World XCO Champion in 2020. Further World Champion titles have been added to the tally in XCO Junior Men and both XCE Men & Women.

The WERX program takes journeys down the trails less travelled. It takes "Race Proven Engineering" to the BIG mountain freeride world. The stress and strain is equal and at the same different to the demand of racing. Riders like Carson Storch, Jaxson Riddle, Olivier Cuvet, Elliott Lapotre, Alex Volokhov, James Doerfling, Brett Tippie, among others journey to the far off reaches of the Gobi Desert, Peru, the Alps, and Nepal in pursuit of the ultimate performance.

WERX development is as much about keeping a rider riding, as riding fast. Either way, pushing the limits. We place immense value on the commitment and dedication of our WERX riders all over the world, all year round; travelling from World Cup to World Cup or going back-country to places with no phone service and epic riding.





RIDER OLIVIER CUVET, ALEX
VOLOKHOV, JP GENDRON,
CARSON STORCH
LOCATION RUX WORLD TOUR,
PACIFIC CITY, OREGON, USA
PHOTO HOSHI YOSHIDA

WERX FAMILY

WERX TEAM RACING



NS BIKES UR TEAM
Downhill

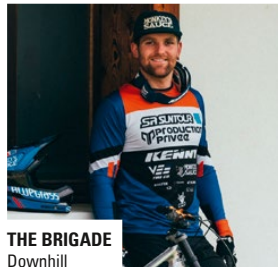

THE BRIGADE
Downhill

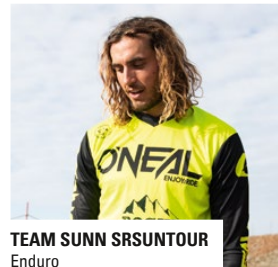

TEAM SUNN SRSUNTOUR
Enduro



CTM RACING
Downhill / Enduro



1VISION TEAM
Downhill



SCOTT SRSUNTOUR TEAM
Enduro

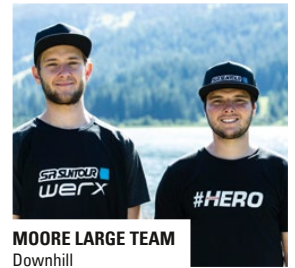

MOORE LARGE TEAM
Downhill

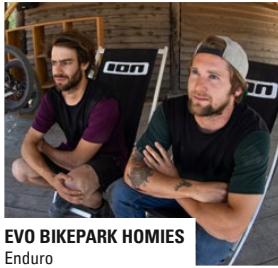

EVO BIKEPARK HOMIES
Enduro



GIANT-SWISS-TEAM
Enduro

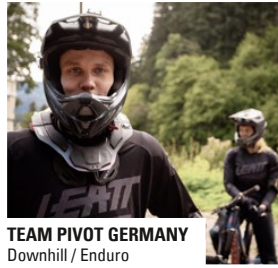

TEAM PIVOT GERMANY
Downhill / Enduro



SCOTT CREUSE OXYGÈNE
Cross Country



LEXWARE MOUNTAINBIKE TEAM
Cross Country



INEOS GRENADIERS TEAM
Cross Country



TEAM VCA KTM ANJOS
Cross Country



CUBE PROFERMETURES
Cross Country



BH WALLONIE
Cross Country

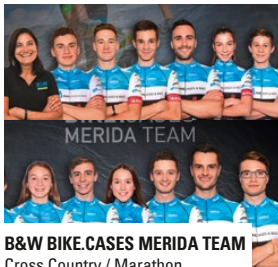

B&W BIKE.CASES MERIDA TEAM
Cross Country / Marathon

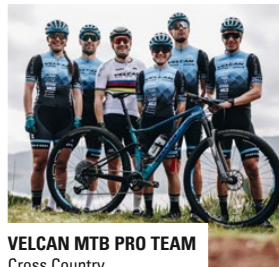

VELCAN MTB PRO TEAM
Cross Country



SIMPLON TEXPA TEAM
Cross Country / Marathon



STOP&GO MTB TEAM
Cross Country / Marathon



KMC FRUIT TO GO
Marathon

TURBO BIKE TEAM Cross Country // FUJI BIKES ROCKETS TEAM Marathon

WERX RIDER



ELLIOTT LAPOTRE
Freeride



WILLIAM ROBERT
Freeride



PETR VINOKUROV
Freeride



TOMAS ZEJDA
Freeride



SAM REYNOLDS
Freeride / Slopestyle



STEFAN GARLICKI
Downhill

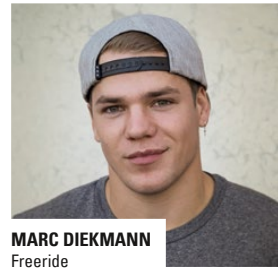

MARC DIEKMANN
Freeride



JAXSON RIDDLE
Freeride



NICOLAS TERRIER
Freeride



JAMES DOERFLING
Freeride



BENOIT GURNEL
Freeride



CARSON STORCH
Freeride



NICO QUÉRÉ
E-MTB



KURTIS DOWNS
Freeride



TOM ISTED
Slopestyle

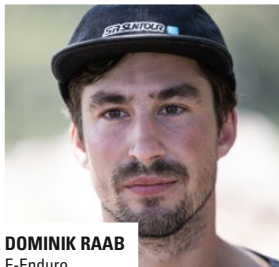

DOMINIK RAAB
E-Enduro



LOUIS REBOUL
Freeride



FLORIAN GROHENS
Freeride



MIKEY HADERER
Freeride / Slopestyle

TOMAS ZEJDA Freeride // NIELS BENSINK Pumptrack

WERX RIDER



MARK MATTHEWS
Freeride



LUCAS HUPPERT
Slopestyle



QUENTIN DERBIER
Enduro / E-MTB



ALEX VOLOKHOV
Freeride

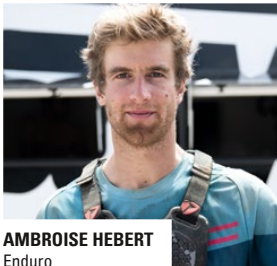

AMBROISE HEBERT
Enduro



ANTOINE BUFFART
Freeride



ANTHONY ROCCI
Freeride



MAKKEN HAUGEN
Freeride

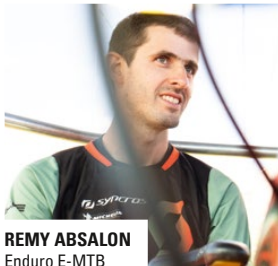

REMY ABSALON
Enduro E-MTB



LIAM MOYNIHAN
Enduro

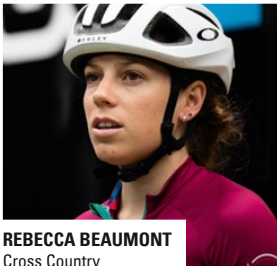

REBECCA BEAUMONT
Cross Country



JORDY SCOTT
Pumptrack / Freeride



OLIVIER CUVET
Freeride



PREMEK TEJCHMAN
Enduro



KYLE WARNER
E-Enduro

WERX AMBASSADORS



PAUL BASAGOITIA
E-MTB



HANS REY
MTB Legend



THOMAS ÖHLER
Enduro



GUIDO TSCHUGG
E-Freeride

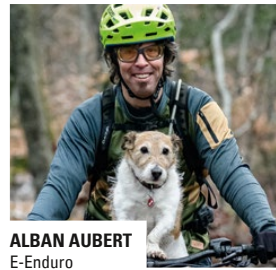

ALBAN AUBERT
E-Enduro



TOBIAS WOGGON
Enduro



DYLAN CRANE
Downhill / Enduro



HARALD PHILIPP
Enduro



DAVID CACHON
Freeride

Fernando Mermolajo



MIKE HOPKINS
Enduro



BRETT TIPPIE
Freeride



GLOSSARY

SUSPENSION FORK OVERVIEW

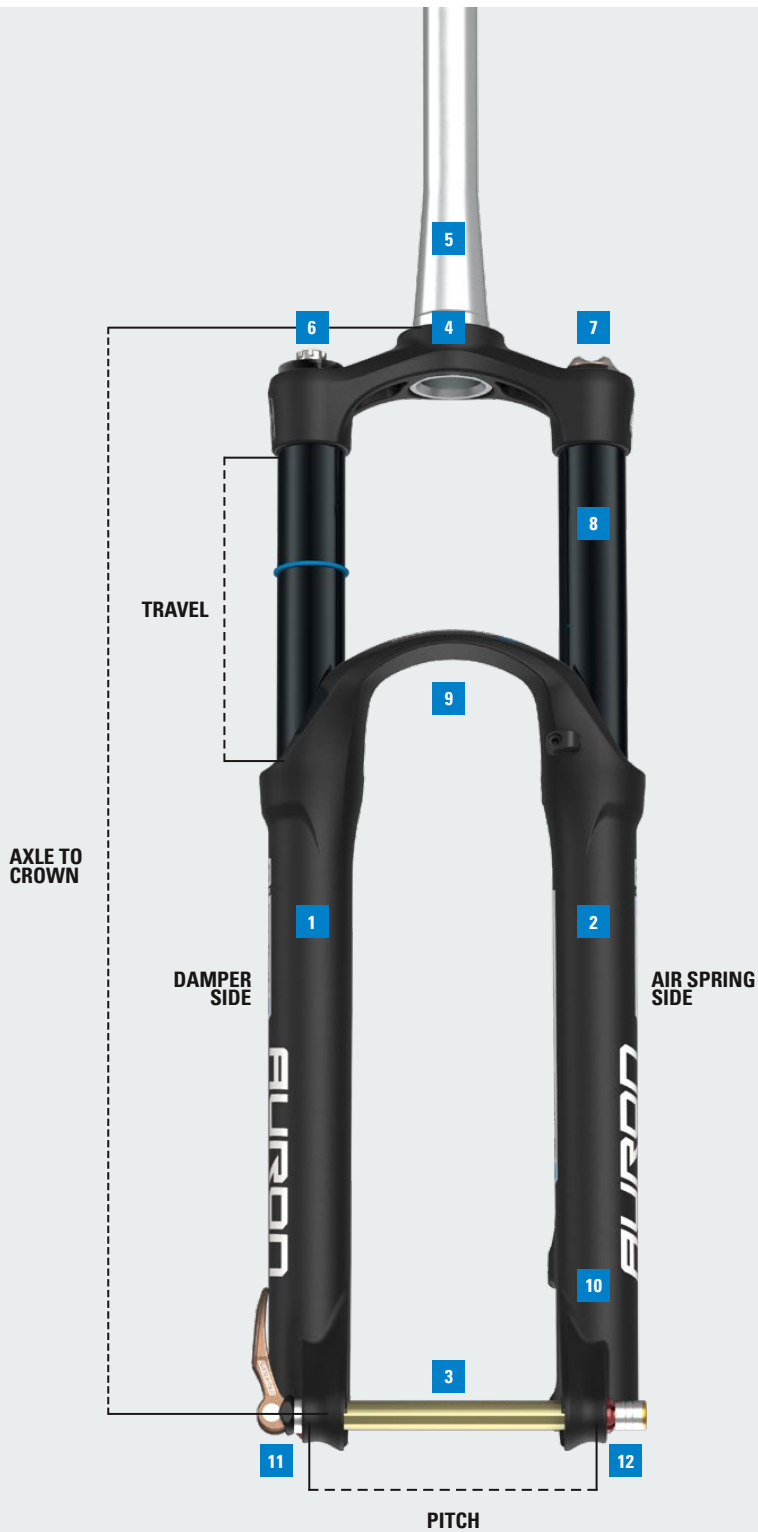

KEY TECHNOLOGYS

- 01 PCS PISTON COMPENSATOR SYSTEM** PAGE 16
MORE TRACTION, CONTROL AND CONSISTENCY
- 02 EQ EQUALIZER SYSTEM** PAGE 18
FOR PRECISE AND EFFORTLESS TUNING
- 03 QLOC SYSTEM** PAGE 92
QUICK RELEASE FOR THRU AXLES
- 04 HOLLOW CROWN**
LIGHTWEIGHT FORGED HOLLOW AND ULTRA-LIGHTWEIGHT CARBON CROWN TECHNOLOGY
- 05 STEERER TUBE**
- 06 COMPRESSION KNOB / LOCK OUT KNOB**
PRELOAD ADJUSTER (NON-DAMPER MODELS)
- 07 AIR VALVE AIR VOLUME ADJUST (AIR MODEL)**
PRELOAD ADJUSTER (COIL MODEL)
- 08 STANCHION TUBE**
- 09 TIRE CLEARANCE**
- 10 BOTTOM CASE / LOWER LEG**
- 11 REBOUND KNOB**
- 12 AIR VALVE (TA MODEL)**

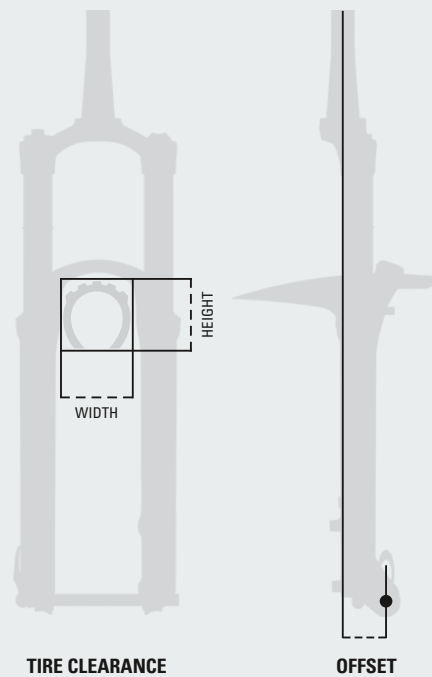

PCS CARTRIDGES

R2C2-PCS



**HIGH AND LOW SPEED
COMPRESSION ADJUST
HIGH AND LOW SPEED
REBOUND
PCS SYSTEM (PISTON
COMPENSATOR SYSTEM)**

Race proven WERX cartridge with new PCS (Piston Compensator system) floating piston provides consistent damping in all conditions, eliminating cavitation

- New high speed compression piston provides a larger adjustable range
- New adjustable high speed rebound design provides fast recovery for improved ride height position
- Updated internal seals greatly improved durability for Trail, Enduro and DH riding
- Forged alloy adjust knobs with integrated design
- Light "Click" index feeling for easy and sure operation



RC2-PCS



**HIGH AND LOW SPEED
COMPRESSION ADJUST
REBOUND ADJUST
PCS SYSTEM
(PISTON COMPENSATOR
SYSTEM)**

Race proven WERX cartridge with new PCS (Piston Compensator system) floating piston provides consistent damping in all conditions, eliminating cavitation

- New high speed compression piston provides a larger adjustable range
- Updated internal seals greatly improved durability for Trail, Enduro and DH riding
- Forged alloy adjust knobs with integrated design
- Light "Click" index feeling for easy and sure operation



RC-PCS



**LOW SPEED COMPRESSION
ADJUST
REBOUND ADJUST
PCS SYSTEM
(PISTON COMPENSATOR
SYSTEM)**

Race proven WERX cartridge with new PCS (Piston Compensator system) floating piston provides consistent damping in all conditions, eliminating cavitation

- Updated internal seals greatly improved durability for Trail, Enduro and DH riding
- Forged alloy adjust knobs with integrated design
- Light "Click" index feeling for easy and sure operation



3CR-PCS / 2CR-PCS

**3 OR 2 POSITIONS OF COMPRESSION ADJUST
LOW SPEED REBOUND ADJUST
PCS SYSTEM (PISTON COMPENSATOR SYSTEM)**

- 2CR with low speed compression at firm setting and open setting. Low speed rebound damping.
- 3CR with low speed compression at firm setting, medium setting and open setting. Low speed rebound damping.
- Forged alloy adjust knobs with integrated design
- Light "Click" index feeling for easy and sure operation

RLRC-PCS

**LOW SPEED COMPRESSION ADJUST
REBOUND ADJUST
REMOTE SPEED LOCK
PCS SYSTEM (PISTON COMPENSATOR SYSTEM)**

- 3-in-1 Lock out + low speed compression & rebound adjust in one cartridge
- Drastic improvement of riding efficiency & its adjustability for cross country & trail ride
- Forged alloy adjust knobs with integrated design
- Light "Click" index feeling for easy and sure operation
- New ergonomic design remote lock lever for faster and easier operation



LORC-PCS

**LOW SPEED COMPRESSION ADJUST
REBOUND ADJUST
SPEED LOCK
PCS SYSTEM (PISTON COMPENSATOR SYSTEM)**

- 3-in-1 Lock out + low speed compression & rebound adjust in one cartridge
- Drastic improvement of riding efficiency & its adjustability for cross country & trail ride
- Forged alloy adjust knobs with integrated design
- Light "Click" index feeling for easy and sure operation



DAMPING ADJUSTMENT



R2C2-PCS

High & low speed compression and High & low speed rebound damping adjusts with blow-off feature along with PCS system.



RC2-PCS

High & low speed compression and low speed rebound damping adjusts with blow-off feature along with PCS system.



RC-PCS

Low speed compression and low speed rebound damping adjusts with blow-off feature along with PCS system.



3CR-PCS

3 positions of compression (firm setting, medium setting and open setting) with low speed rebound adjust along with PCS system.



2CR-PCS

2 positions of compression (firm setting and open setting) with low speed rebound adjust along with PCS system.



RLRC-PCS

Hydraulic Remote Lockout with low speed compression and low speed rebound damping adjusts with blow-off feature along with PCS system.



LORC-PCS

Hydraulic Lockout with low speed compression and low speed rebound damping adjusts with blow-off feature along with PCS system.



RC2

High & low speed compression and low speed rebound damping adjusts with blow-off feature.

APPLICATION TABLE	R2C2	RC2	3CR	2CR	RC	RLRC	LORC	RLR	LOR	RL	LO	HLO	NLO
RUX	●	●	-	-	-	-	-	-	-	-	-	-	-
DUR0LUX	●	●	-	-	●	-	-	-	-	-	-	-	-
AURON	-	●	-	-	-	●	●	-	-	-	-	-	-
AION	-	-	-	-	●	-	●	●	●	-	-	-	-
ZERON35	-	-	-	-	●	-	-	●	●	-	-	-	-
AXON	-	-	-	-	-	●●	●●	●	●	-	-	-	-
EPIXON9	-	-	-	-	-	-	-	●	●	-	-	-	-
RAIDON	-	-	-	-	-	-	-	●	●	-	-	-	-
XCR	-	-	-	-	-	-	-	●	●	●	●	-	-
XCM	-	-	-	-	-	-	-	-	●	●	●	●	●
XCT	-	-	-	-	-	-	-	-	-	-	-	●	●
MOBIE35	-	-	●	●	-	-	-	-	-	-	-	-	-
MOBIE34	-	-	-	●	-	-	-	-	-	-	-	-	-
MOBIE34 CGO	-	-	-	-	-	-	-	-	-	-	●	-	-
MOBIE45/25	-	-	-	-	-	-	-	●	●	-	-	-	-
MOBIEA32	-	-	-	-	-	-	-	-	-	●	●	-	●
GVX	-	-	-	-	-	-	-	●	●	-	-	-	-
NRX	-	-	-	-	-	-	-	●	●	●	●	-	-
NCX32/NCX/TR-HSI	-	-	-	-	-	-	-	-	-	●	●	●	-
NVX	-	-	-	-	-	-	-	-	-	●	-	-	●
NEX	-	-	-	-	-	-	-	-	-	●	-	●	●
CR	-	-	-	-	-	-	-	-	-	-	●	●	-

● PCS CARTRIDGE



RC
Low speed compression and low speed rebound damping adjusts with blow-off feature.



2CR
2 positions of compression (firm setting and open setting) with low speed rebound adjust.



RLRC
Hydraulic Remote Lockout with adjustable rebound and compression damping with blow-off feature.



LORC
Hydraulic Lockout with adjustable rebound and compression damping with blow-off feature.



RLR
Hydraulic Remote Lockout with adjustable rebound damping with blow-off feature.



LOR
Hydraulic Lockout with adjustable rebound damping with blow-off feature.



RL
Hydraulic Remote Lockout with fixed rebound damping with blow-off feature.



LO
Hydraulic Lockout with fixed rebound damping with blow-off feature.



NLO
Hydraulic Lockout with fixed rebound damping.



HLO
Hydraulic Lockout without rebound damping.



RIDER: MAKKEN HAUGEN
 LOCATION: EVO BIKE PARK, DIGNE-LES-BAINS, FRANCE
 PHOTO: HOSHI YOSHIDA

SPRING SYSTEM



AIR EQ
 Dual air spring system



AIR
 Standard air spring



COIL ADJUSTABLE
 Coil spring with adjustable
 preload



COIL
 Coil spring

APPLICATION TABLE	AIR EQ	AIR	COIL ADJUSTABLE	COIL
RUX	-	●	-	-
DUROLUX	●	-	-	-
AURON	●	-	-	-
AION	-	●	-	-
ZERON35	-	●	●	-
AXON	●	●	-	-
EPIXON9	-	●	-	-
RAIDON	-	●	-	-
XCR	-	●	●	-
XCM	-	●	●	-
XCT	-	●	●	-
XCE	-	-	●	-
M3010	-	-	●	●
MOBIE45/34/25	-	●	●	-
MOBIE35	●	-	-	-
MOBIEA32	-	-	●	-
GVX	-	●	-	-
NRX	-	●	●	-
NCX32/NCX/TR-HSI	-	●	●	-
NVX	-	-	●	-
NEX	-	-	●	-
CR	-	-	● +MCU w/P	●

ADJUSTABLE AIR CHAMBER VOLUME



VOLUME SPACER LOGIC

Adjust your spring curve by using different amount of rubber volume spacers. This function allows the rider to choose between a more linear or a more progressive characteristic curve. More spacers for more progression. Less spacers for more comfort. Visit www.srsuntour.com for tech videos and product manuals with detailed information.

EXAMPLE SPRING CHARACTERISTIC: DUROLUX EQ 29, 160mm travel

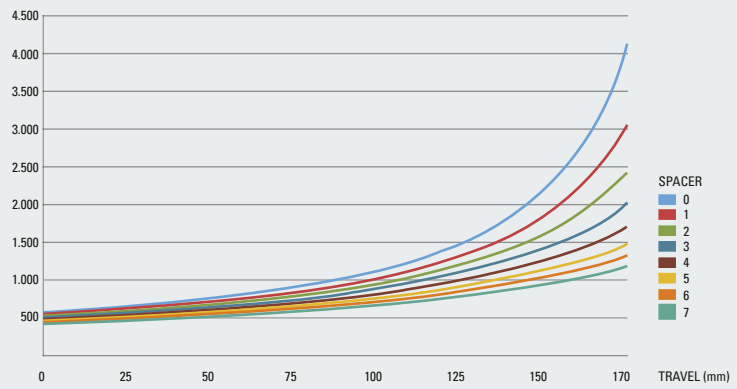

LOCK OUT LEVERS



RL22-DUAL-L-2C-22
DUAL REMOTE LOCKOUT LEVER

- Rebound
- forged alloy adjust knob
- light „CLICK“ index feeling for easy and sure operation



RL22-SINGLE-L-2C-22
REMOTE LOCKOUT LEVER

- Rebound
- forged alloy adjust knob
- light „CLICK“ index feeling for easy and sure operation



RL22-SINGLE-U-2C-22
REMOTE LOCKOUT LEVER

- Rebound
- forged alloy adjust knob
- light „CLICK“ index feeling for easy and sure operation



RIDER ISAURE MEDDE
LOCATION WORLD CUP 2021
LES GETS, FRANCE
PHOTO RÉMY VROONEN

STANCHION

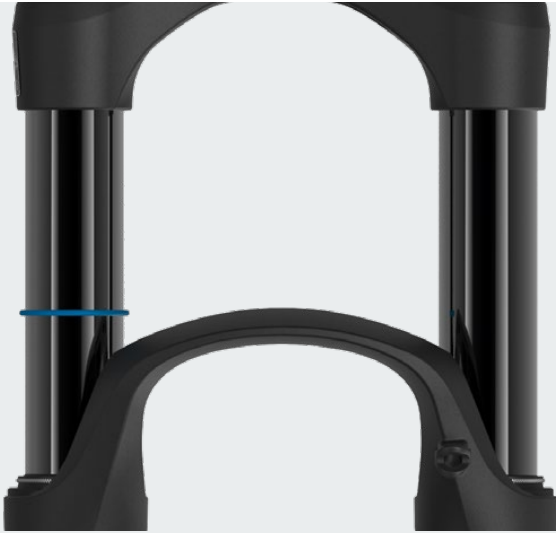

HARD ANODIZED BLACK A7 / A6000 series aluminum

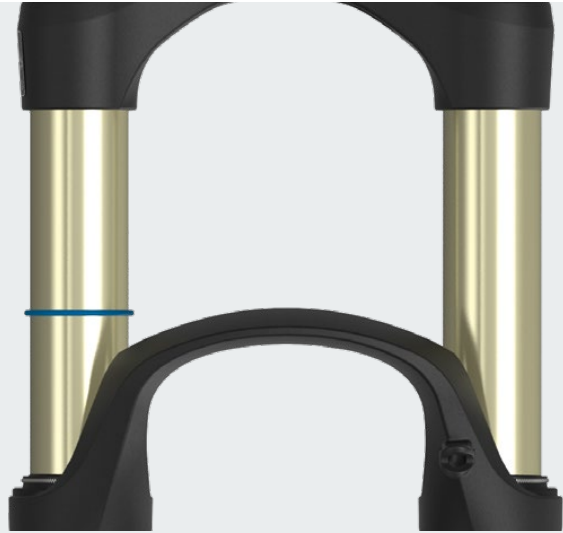

HARD ANODIZED GOLD A7 / A6000 series

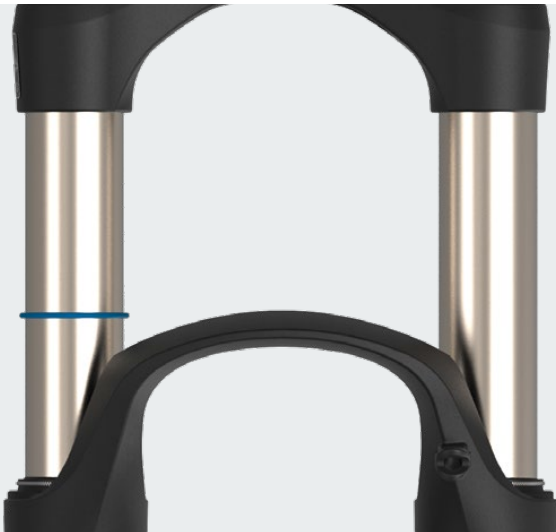

NI-PLATING STKM

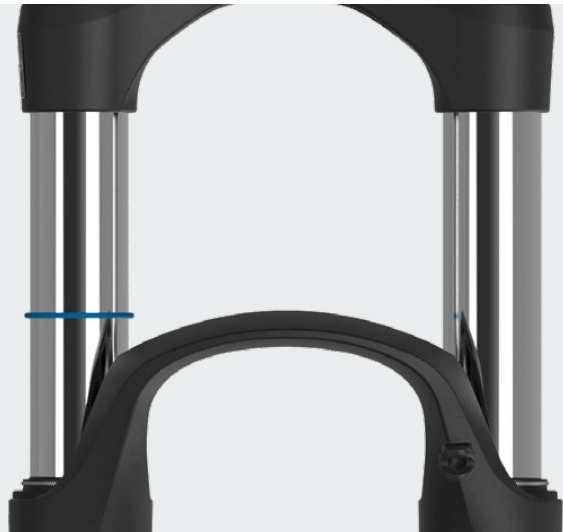

CR-PLATING STKM

BOTTOM CASE COLORS



MATT BLACK
Color code YS727



GLOSS BLACK
Color code YS728

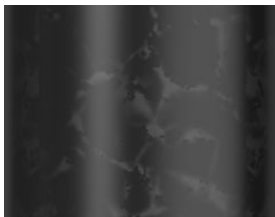

CARBON BLACK GLOSS
UD Finish (AXON Werx)

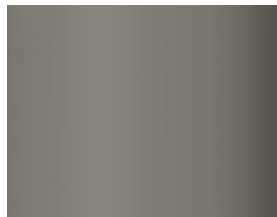

TEAM GRAY
Color code YS7341



GLOSS WHITE
Color code YS701

Q-LOC AND THRU AXLE SYSTEMS



Q-LOC is a patented quick release system for thru axles fully deserving of the name "quick". Q-LOC 2 is the logical evolutionary step, guaranteeing 100% compatibility with all kinds of hub axle designs. A simple push and a little twist of the nut enables a quick removal of the axle. Exchanging the axle is as fast as extracting the axle thanks to the patented expander design which smoothly passes the thru axle and latches safely with a reassuring click sound. Safety and speed is crucial when it comes to pressurised wheel changes during a race. Q-LOC2 offers both in a super lightweight axle (Q-LOC2-Ti 70g).



20QLC2
 Ø20mm, O.L.D.: 110mm
 Weight: 140g



20LH-110
 Ø20mm, O.L.D.: 110mm
 Weight: 96g



15QLC2 TI / 15QLC2TI-110
 Ø15mm, O.L.D.: 100mm / 110mm
 Weight: 68g / 71g



15QLC2 / 15QLC2-110
 Ø15mm, O.L.D.: 100mm
 Weight: 112g



15QLC32 / 15QLC32-110
 Ø15mm, O.L.D.: 100mm / 110mm
 Weight: 118g / 122g



15QLC32S
 Ø15mm, O.L.D.: 100mm
 Weight: 108g



15AH2 / 15AH2-110 (TOOL TYPE)
 Ø15mm, O.L.D.: 100mm / 110mm
 Weight: 50g



15LH / 15LH-110
 Ø15mm, O.L.D.: 100mm (15LH),
 110mm (15LH-110)
 Weight: 88g (15LH), 91g (15LH-110)



12AH2 (TOOL TYPE)
 Ø12mm, O.L.D.: 100mm

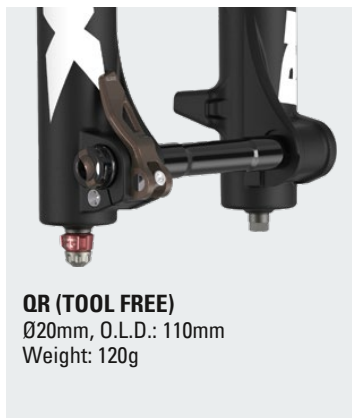

QR (TOOL FREE)
 Ø20mm, O.L.D.: 110mm
 Weight: 120g



T (TOOL TYPE)
 Ø20mm, O.L.D.: 110mm
 Weight: 120g

ASSEMBLY INSTRUCTIONS

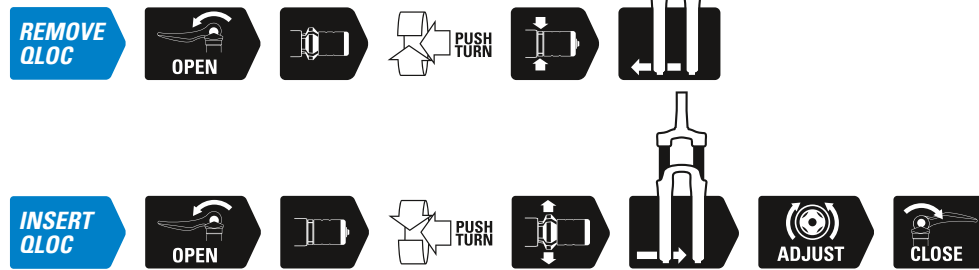

WATCH THE VIDEO TUTORIAL!

APPLICATION TABLE	T	QR	15AH2	15LH / 15LH-110	12AH	15AH2-110	20QLC2	20QLC2-110	20LH-110	15QLC2	15QLC2-110	15QLC32	15QLC32-110	15QLC2TI	15QLC2TI-110	15QLC32S
RUX	●	○	-	-	-	-	-	-	-	-	-	-	-	-	-	-
DUROLUX36	-	-	-	-	-	-	-	-	-	-	-	-	●	-	●	-
DUROLUX38	-	-	-	-	-	-	-	-	●	-	-	-	-	-	-	-
AURON	-	-	-	-	-	-	-	-	-	-	-	-	-	-	●	-
AION	-	-	-	-	-	-	-	-	-	-	-	-	●	-	-	-
ZERON35	-	-	-	-	-	-	-	-	-	-	-	-	●	-	-	-
AXON WERX	-	-	-	-	-	-	-	-	-	-	-	-	-	●	●	-
AXON ELITE	-	-	-	-	-	-	-	-	-	-	-	-	-	●	●	-
AXON	-	-	-	-	-	-	-	-	-	●	●	●	-	○	-	-
RAIDON	-	-	-	-	-	-	-	-	-	-	-	●	●	-	-	-
XCR	-	-	-	-	-	○	-	-	-	-	-	●	●	-	-	-
XCM	-	-	●	-	-	●	-	-	-	-	-	○	●	-	-	-
MOBIE35	-	-	-	●	-	-	-	-	-	-	-	-	-	-	-	-
MOBIE45/34/25	-	-	-	-	-	●	-	-	-	-	-	●	-	-	-	-
MOBIEA32	-	-	●	-	-	-	-	-	-	-	-	-	-	-	-	-
GVX	-	-	●	-	○	-	-	-	-	-	-	-	-	-	-	-
NRX	-	-	-	-	-	-	-	-	-	-	-	-	-	-	-	●
NCX	-	-	-	-	-	-	-	-	-	-	-	-	-	-	-	●
NEX-E25	-	-	-	-	-	-	-	-	-	-	-	-	-	-	-	●

● standard ○ optional

FEATURE	15QLC2TI / 15QLC2TI-110	15QLC2 / 15QLC2-110	15QLC32 / 15QLC32-110	15QLC32S	15LH / 15LH-110	20QLC	20LH-110	15AH2 / 15AH2-110 (TOOL TYPE)
ONE TOUCH RELEASE DESIGN	Yes	Yes	Yes	Yes	No	Yes	No	No
QUICK LEVER	Alloy with CNC machined hole	Alloy with print	Alloy with print	Alloy with print	Alloy with print	Alloy with print	Alloy with print	-
COMPATIBLE O.L.D.	100mm / 110mm	100mm / 110mm	100mm / 110mm	100mm	100mm / 110mm	110mm	110mm	100mm, 110mm
THROUGH AXLE DIAMETER	15mm	15mm	15mm	15mm	15mm	20mm	20mm	15mm
THROUGH AXLE MATERIAL	Alloy (A7075)	Alloy	Cr-mo	Alloy	Alloy	Cr-mo	Alloy	Alloy
QUICK AXLE MATERIAL	Titanium	Cr-mo	Cr-mo	Cr-mo	Cr-mo	Cr-mo	Cr-mo	-
WEIGHT	70g / 72g	112g / 116g	118g / 122g	108g	88g / 91g	140g	96g	NA
PART CODE	FKA069-15	FKA069-05	FKA069-25/26	FKA097-25/26	FKA116-12/ 02	FKA068-05	FKA123-00	FKA117-02

LIGHTWEIGHT HOLLOW CROWN



HOLLOW CROWN

HOLLOW CROWN TECHNOLOGY
Lightweight forged Hollow Crown Technology



CARBON

CARBON CROWN TECHNOLOGY
Ultra-Lightweight Carbon Crown



STANCHION DIAMETER

- 38
mm
- 36
mm
- 35
mm
- 34
mm
- 32
mm
- 30
mm
- 28
mm
- 25.4
mm
- 25
mm

WHEEL SIZE

- 29"
- 700^C
- 27.5"
- 26"
- 24"
- 20"

STEERER TUBE



1.5"-1 1/8" TAPER
 CTS (Conical Tapered Steerer)
 Upper 1-1/8", Lower 1.5"
 Material: Alloy / Carbon / STKM



1.8"-1 1/8" TAPER
 CTS (Conical Tapered Steerer)
 Upper 1-1/8", Lower 1.8"
 Material: Alloy



1-1/8"
 TS: Upper 1-1/8"
 Material: Alloy / cr-mo / STKM

BRAKE TYPE



P
 Pivot brake type aka. V-Brake

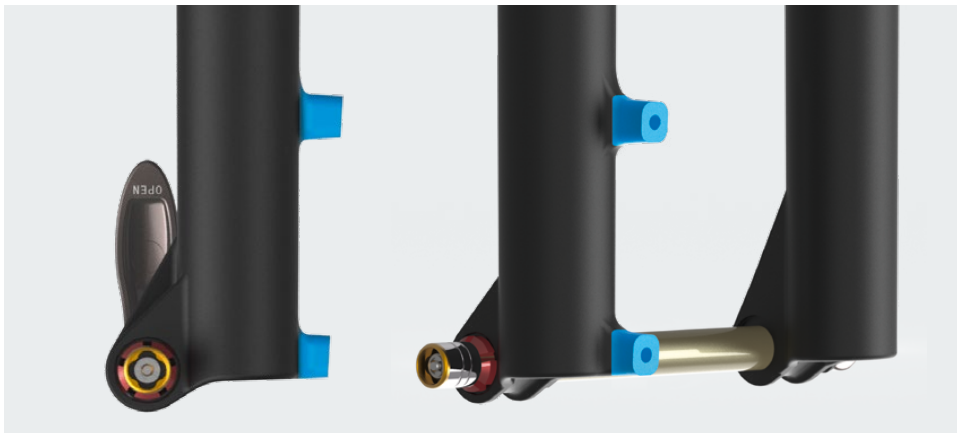

DS
 Disc brake type

MAX. DISC BRAKE ROTOR SIZES*

203 mm MAX DISC FOR **34 mm** **35 mm** **36 mm** **38 mm**

180 mm MAX DISC FOR **28 mm** **30 mm** **32 mm**

160 mm MAX DISC FOR **254 mm**

*Related to stanchion tube diameter

HEAD LAMP MOUNT



INTEGRATED TYPE ON FORK CROWN
With smooth cable routing



INTEGRATED TYPE ON FORK BRACE



UNIVERSAL MOUNT
Bolt-on

SHORT FENDER



SHORT FENDER MOUNT
Detachable integrated short fender



FENDER MOUNTS



LONG FENDER TYPE
Disc brake type

CABLE GUIDE

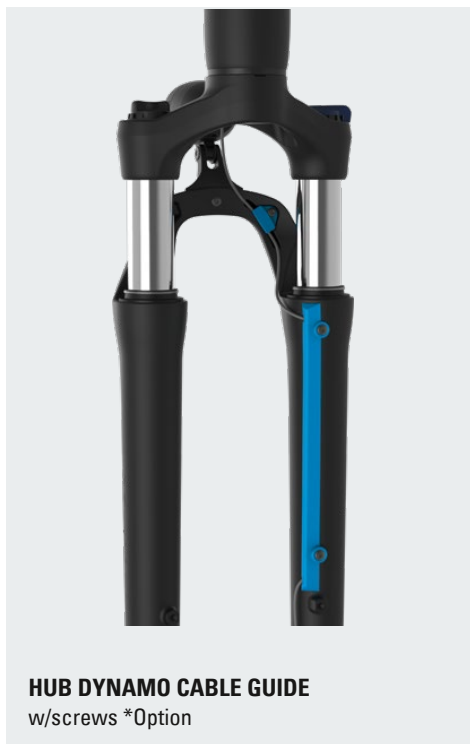

HUB DYNAMO CABLE GUIDE
w/screws *Option

APPLICATION TABLE	ON FORK CROWN	ON FORK BRACE	UNIVERSAL MOUNT	CABLE GUIDE HUB DYNAMO
XCR32-ATB	●	-	-	-
XCM32-ATB	●	-	-	-
XCT	-	-	●	-
XCE	-	-	●	-
M3010	-	-	●	●
MOBIE35/45/34/25/A32	●	-	-	-
NCX	-	●	-	●
NCX32	●	-	-	-
TR-HSI	-	-	●	-
NVX	●	-	-	-
NEX-E25-C	●	-	-	●
NEX-E25	-	●	-	●
NEX	-	●	-	●
CR85-E25	-	●	●	●
CR8	-	●	●	●



LONG FENDER TYPE
V-brake

APPLICATION TABLE	SHORT FENDER TYPE	LONG FENDER TYPE DISC BRAKE	LONG FENDER TYPE V-BRAKE
RUX BOOST	●	-	-
DUROLUX BOOST	●	●	-
AURON BOOST	●	●	-
AION BOOST	●	●	-
ZERON35 BOOST	●	●	-
AXON34 WERX/ ELITE BOOST	●	-	-
AXON34 BOOST	●	●	-
AXON32 BOOST	●	●	-
RAIDON34 BOOST	●	●	-
RAIDON32 BOOST	●	●	-
XCR34 BOOST	●	●	-
XCR32 BOOST	●	●	-
XCR32-ATB	-	●	-
XCM34 BOOST	●	-	-
XCM32	-	●	-
XCM32-ATB	-	●	-
M3010	-	-	●
MOBIE35	●	●	-
MOBIE45/34/25/A32	-	●	-
GVX	●	●	-
NRX	-	●	●
NCX	-	●	●
NCX32	-	●	-
NVX	-	●	-
NEX	-	●	●
CR	-	●	●



RIDER SAM REYNOLDS
LOCATION QUEENSTOWN, NZ
PHOTO HOSHI YOSHIDA

SUSPENSION COSMOS 2K22



DOWNHILL

FREERIDE

ENDURO

TRAIL

CROSS COUNTRY

RIDING STYLE

CASUAL MTB

GRAVEL

CROSS / TREKKING

URBAN / UTILITY

SPECIFICATIONS

// 2K22

 SPECIALIZED



RIDER DAN SLACK
LOCATION DH WORLD CUP 2021
MARIBOR, SLOVENIA
PHOTO RÉMY VROONEN

38 Boost R2C2-PCS 27.5"

R2C2-PCS 27.5"



E-BIKE READY



E-BIKE READY



MODEL YEAR	MODEL NAME	MAIN SPECIFICATIONS							CROWN		STANCHION			STEERER TUBE	AXLE		BOTTOM CASE / BRAKE			
		Weight (g) w/o axle	Wheel	Travel (mm)	Damper	Spring	Axle to crown (mm)	Offset (mm)	Mat.	Method	DIA (mm)	Mat.	Finish	Pitch (mm)	Size Material	O.L.D.	Axle	Mat.	Max rotor DIA.	Brake mount
SF18	RUX38-Boost R2C2-PCS DS T 27.5"	2870	27.5"	200	R2C2-PCS	AIR	596	50	Alloy	Hollow Forged	38	Alloy	Hard anodized, Black	145	1.5"to1-1/8" tapered(CTS), Alloy	ø20-110	20mm Tool type/ (OP) 20mm Tool free	Mg	203mm	Post 203 Direct
SF18	RUX38-Boost RC2-PCS DS T 27.5"	2845	27.5"	200	RC2-PCS	AIR	596	50	Alloy	Hollow Forged	38	Alloy	Hard anodized, Black	145	1.5"to1-1/8" tapered(CTS), Alloy	ø20-110	20mm Tool type/ (OP) 20mm Tool free	Mg	203mm	Post 203 Direct
SF17	RUX R2C2-PCS DS T 27.5"	2867	27.5"	200	R2C2-PCS	AIR	586	50	Alloy	Forged	38	Alloy	Hard anodized, Black	145	1.5"to1-1/8" tapered(CTS), Alloy	ø20-110	20mm Tool type/ (OP) 20mm Tool free	Mg	203mm	Post 203 Direct
SF17	RUX RC2-PCS DS T 27.5"	2843	27.5"	200	RC2-PCS	AIR	586	50	Alloy	Forged	38	Alloy	Hard anodized, Black	145	1.5"to1-1/8" tapered(CTS), Alloy	ø20-110	20mm Tool type/ (OP) 20mm Tool free	Mg	203mm	Post 203 Direct
SF17	RUX R2C2-PCS DS T 26"	2884	26"	200	R2C2-PCS	AIR	586	44	Alloy	Forged	38	Alloy	Hard anodized, Black	145	1.5"to1-1/8" tapered(CTS), Alloy	ø20-110	20mm Tool type/ (OP) 20mm Tool free	Mg	203mm	Post 203 Direct
SF17	RUX RC2-PCS DS T 26"	2860	26"	200	RC2-PCS	AIR	586	44	Alloy	Forged	38	Alloy	Hard anodized, Black	145	1.5"to1-1/8" tapered(CTS), Alloy	ø20-110	20mm Tool type/ (OP) 20mm Tool free	Mg	203mm	Post 203 Direct

DUROLUX

38 Boost EQ ABS
R2C2-PCS 29"



MODEL YEAR	MODEL NAME	MAIN SPECIFICATIONS							CROWN		STANCHION			STEERER TUBE		AXLE		BOTTOM CASE / BRAKE		
		Weight (g) w/o axle	Wheel	Travel (mm)	Damper	Spring	Axle to crown (mm)	Offset (mm)	Mat.	Method	DIA (mm)	Mat.	Finish	Pitch (mm)	Size Material	O.L.D.	Axle	Mat.	Max rotor DIA.	Brake mount
SF21	DUROLUX38-Boost EQ ABS R2C2-PCS DS 20LH-110 29"	-	29"x2.6"	160 170 180	R2C2-PCS	AIR (EQ)	620.5	44	Alloy	Hollow Forged	38	Alloy	Hard anodized, Black	145	1.5"to1-1/8" tapered(CTS), Alloy/ (OP) 1.8"to 1-1/8" tapered(CTS), Alloy	ø20-110	20LH-110	Mg	220mm	Post 203 Direct
SF21	DUROLUX38-Boost EQ R2C2-PCS DS 20LH-110 29"	-	29"x2.6"	160 170 180	R2C2-PCS	AIR (EQ)	620.5	44	Alloy	Hollow Forged	38	Alloy	Hard anodized, Black	145	1.5"to1-1/8" tapered(CTS), Alloy/ (OP) 1.8"to 1-1/8" tapered(CTS), Alloy	ø20-110	20LH-110	Mg	220mm	Post 203 Direct
SF21	DUROLUX38-Boost EQ RC2-PCS DS 20LH-110 29"	2500	29"x2.6"	160 170 180	RC2-PCS	AIR (EQ)	620.5	44	Alloy	Hollow Forged	38	Alloy	Hard anodized, Black	145	1.5"to1-1/8" tapered(CTS), Alloy/ (OP) 1.8"to 1-1/8" tapered(CTS), Alloy	ø20-110	20LH-110	Mg	220mm	Post 203 Direct
SF21	DUROLUX38-Boost EQ RC2-PCS DS 20LH-110 29"	2510	29"x2.6"	160 170 180	RC2-PCS	AIR (EQ)	620.5	44	Alloy	Hollow Forged	38	Alloy	Hard anodized, Black	145	1.5"to1-1/8" tapered(CTS), Alloy/ (OP) 1.8"to 1-1/8" tapered(CTS), Alloy	ø20-110	20LH-110	Mg	220mm	Post 203 Direct

36 Boost EQ
R2C2-PCS 27.5"



DUROLUX
FREERIDE / ENDURO

MODEL YEAR	MODEL NAME	MAIN SPECIFICATIONS							CROWN		STANCHION			STEERER TUBE		AXLE		BOTTOM CASE / BRAKE		
		Weight (g) w/o axle	Wheel	Travel (mm)	Damper	Spring	Axle to crown (mm)	Offset (mm)	Mat.	Method	DIA (mm)	Mat.	Finish	Pitch (mm)	Size Material	O.L.D.	Axle	Mat.	Max rotor DIA.	Brake mount
SF21	DUROLUX36-Boost EQ R2C2-PCS DS 15QLC2Ti-110 29"	2120	29"x2.6"	150 160 170	R2C2-PCS	AIR (EQ)	590	51/44	Alloy	Hollow Forged	36	Alloy	Hard anodized, Black	145	1.5"to1-1/8" tapered(CTS), Alloy/ (OP) 1.8"to1-1/8" tapered(CTS), Alloy	ø15-110	15QLC2Ti-110	Mg	203mm	Post 180 Direct
SF21	DUROLUX36-Boost EQ RC2-PCS DS 15QLC2Ti-110 29"	2158	29"x2.6"	150 160 170	RC2-PCS	AIR (EQ)	590	51/44	Alloy	Hollow Forged	36	Alloy	Hard anodized, Black	145	1.5"to1-1/8" tapered(CTS), Alloy/ (OP) 1.8"to1-1/8" tapered(CTS), Alloy	ø15-110	15QLC2Ti-110	Mg	203mm	Post 180 Direct
SF21	DUROLUX36-Boost EQ RC-PCS DS 15QLC32-110 29"	-	29"x2.6"	150 160 170	RC-PCS	AIR (EQ)	590	51/44	Alloy	Solid	36	Alloy	Hard anodized, Black	145	1.5"to1-1/8" tapered(CTS), Alloy/ (OP) 1.8"to1-1/8" tapered(CTS), Alloy	ø15-110	15QLC32-110	Mg	203mm	Post 180 Direct
SF21	DUROLUX36-Boost EQ R2C2-PCS DS 15QLC2Ti-110 27.5"	2117	27.5"x2.6"	160 170 180	R2C2-PCS	AIR (EQ)	578	44	Alloy	Hollow Forged	36	Alloy	Hard anodized, Black	145	1.5"to1-1/8" tapered(CTS), Alloy/ (OP) 1.8"to1-1/8" tapered(CTS), Alloy	ø15-110	15QLC2Ti-110	Mg	203mm	Post 180 Direct
SF21	DUROLUX36-Boost EQ RC2-PCS DS 15QLC2Ti-110 27.5"	2155	27.5"x2.6"	160 170 180	RC2-PCS	AIR (EQ)	578	44	Alloy	Hollow Forged	36	Alloy	Hard anodized, Black	145	1.5"to1-1/8" tapered(CTS), Alloy/ (OP) 1.8"to1-1/8" tapered(CTS), Alloy	ø15-110	15QLC2Ti-110	Mg	203mm	Post 180 Direct
SF21	DUROLUX36-Boost EQ RC-PCS DS 15QLC32-110 27.5"	-	27.5"x2.6"	160 170 180	RC-PCS	AIR (EQ)	578	44	Alloy	Solid	36	Alloy	Hard anodized, Black	145	1.5"to1-1/8" tapered(CTS), Alloy/ (OP) 1.8"to1-1/8" tapered(CTS), Alloy	ø15-110	15QLC32-110	Mg	203mm	Post 180 Direct

SPECIFICATIONS

// 2102



35 Boost EQ RC2-PCS 29"



MODEL YEAR	MODEL NAME	MAIN SPECIFICATIONS					CROWN			STANCHION			STEERER TUBE		AXLE		BOTTOM CASE / BRAKE			
		Weight (g) w/o axle	Wheel	Travel (mm)	Damper	Spring	Axle to crown (mm)	Offset (mm)	Mat.	Method	DIA (mm)	Mat.	Finish	Pitch (mm)	Size Material	O.L.D.	Axle	Mat.	Max rotor DIA.	Brake mount
SF21	AURON35-Boost EQ RC2-PCS DS 15QLC2Ti-110 29"	2140	29"x2.4"	130/140/150/160	RC2-PCS	AIR (EQ)	580	51/44	Alloy	Forged	35	Alloy	Hard anodized, Black	145	1.5"to1-1/8" tapered(CTS), Alloy	ø15-110	15QLC2Ti-110	Mg	203mm	Post 180 Direct
SF21	AURON35-Boost EQ RLRC-PCS DS 15QLC2Ti-110 29"	2142	29"x2.4"	130/140/150/160	RLRC-PCS	AIR (EQ)	580	51/44	Alloy	Forged	35	Alloy	Hard anodized, Black	145	1.5"to1-1/8" tapered(CTS), Alloy	ø15-110	15QLC2Ti-110	Mg	203mm	Post 180 Direct
SF21	AURON35-Boost EQ LORC-PCS DS 15QLC2Ti-110 29"	2145	29"x2.4"	130/140/150/160	LORC-PCS	AIR (EQ)	580	51/44	Alloy	Forged	35	Alloy	Hard anodized, Black	145	1.5"to1-1/8" tapered(CTS), Alloy	ø15-110	15QLC2Ti-110	Mg	203mm	Post 180 Direct
SF21	AURON35-Boost EQ RC2-PCS DS 15QLC2Ti-110 27.5"	2100	27.5"x2.8"	130/140/150/160	RC2-PCS	AIR (EQ)	565.5	51/44	Alloy	Forged	35	Alloy	Hard anodized, Black	145	1.5"to1-1/8" tapered(CTS), Alloy	ø15-110	15QLC2Ti-110	Mg	203mm	Post 180 Direct
SF21	AURON35-Boost EQ RLRC-PCS DS 15QLC2Ti-110 27.5"	2120	27.5"x2.8"	130/140/150/160	RLRC-PCS	AIR (EQ)	565.5	51/44	Alloy	Forged	35	Alloy	Hard anodized, Black	145	1.5"to1-1/8" tapered(CTS), Alloy	ø15-110	15QLC2Ti-110	Mg	203mm	Post 180 Direct
SF21	AURON35-Boost EQ LORC-PCS DS 15QLC2Ti-110 27.5"	2100	27.5"x2.8"	130/140/150/160	LORC-PCS	AIR (EQ)	565.5	51/44	Alloy	Forged	35	Alloy	Hard anodized, Black	145	1.5"to1-1/8" tapered(CTS), Alloy	ø15-110	15QLC2Ti-110	Mg	203mm	Post 180 Direct

35-EVO Boost LOR-PCS 29"



MODEL YEAR	MODEL NAME	MAIN SPECIFICATIONS							CROWN		STANCHION		STEERER TUBE		AXLE		BOTTOM CASE / BRAKE			
		Weight (g) w/o axle	Wheel	Travel (mm)	Damper	Spring	Axle to crown (mm)	Offset (mm)	Mat.	Method	DIA (mm)	Mat.	Finish	Pitch (mm)	Size Material	O.L.D.	Axle	Mat.	Max rotor DIA.	Brake mount
SF20	AION35-EVO-Boost RC-PCS DS 15QLC32-110 29"	2135	29"x2.4"	120 130 140 150	RC-PCS	AIR	580	51/44	Alloy	Forged	35	Alloy	Hard anodized, Black	145	1.5"to1-1/8" tapered(CTS), Alloy/(OP) 1.8"to1-1/8" tapered(CTS), Alloy	ø15-110	15QLC32-110	Mg	203mm	Post 180 Direct
SF20	AION35-EVO-Boost RLR-PCS DS 15QLC32-110 29"	2140	29"x2.4"	120 130 140 150	RLR-PCS	AIR	580	51/44	Alloy	Forged	35	Alloy	Hard anodized, Black	145	1.5"to1-1/8" tapered(CTS), Alloy/(OP) 1.8"to1-1/8" tapered(CTS), Alloy	ø15-110	15QLC32-110	Mg	203mm	Post 180 Direct
SF20	AION35-EVO-Boost LOR-PCS DS 15QLC32-110 29"	2142	29"x2.4"	120 130 140 150	LOR-PCS	AIR	580	51/44	Alloy	Forged	35	Alloy	Hard anodized, Black	145	1.5"to1-1/8" tapered(CTS), Alloy/(OP) 1.8"to1-1/8" tapered(CTS), Alloy	ø15-110	15QLC32-110	Mg	203mm	Post 180 Direct
SF20	AION35-EVO-Boost RC-PCS DS 15QLC32-110 27.5"	2130	27.5"x2.8"	130 140 150 160	RC-PCS	AIR	565.5	51/44	Alloy	Forged	35	Alloy	Hard anodized, Black	145	1.5"to1-1/8" tapered(CTS), Alloy/(OP) 1.8"to1-1/8" tapered(CTS), Alloy	ø15-110	15QLC32-110	Mg	203mm	Post 180 Direct
SF20	AION35-EVO-Boost RLR-PCS DS 15QLC32-110 27.5"	2135	27.5"x2.8"	130 140 150 160	RLR-PCS	AIR	565.5	51/44	Alloy	Forged	35	Alloy	Hard anodized, Black	145	1.5"to1-1/8" tapered(CTS), Alloy/(OP) 1.8"to1-1/8" tapered(CTS), Alloy	ø15-110	15QLC32-110	Mg	203mm	Post 180 Direct
SF20	AION35-EVO-Boost LOR-PCS DS 15QLC32-110 27.5"	2137	27.5"x2.8"	130 140 150 160	LOR-PCS	AIR	565.5	51/44	Alloy	Forged	35	Alloy	Hard anodized, Black	145	1.5"to1-1/8" tapered(CTS), Alloy/(OP) 1.8"to1-1/8" tapered(CTS), Alloy	ø15-110	15QLC32-110	Mg	203mm	Post 180 Direct

ZERON35

ENDURO / TRAIL

29"

27.5"

35mm

35 Boost RC 29"



MODEL YEAR	MODEL NAME	MAIN SPECIFICATIONS							CROWN		STANCHION				STEERER TUBE		AXLE		BOTTOM CASE / BRAKE	
		Weight (g) w/o axle	Wheel	Travel (mm)	Damper	Spring	Axle to crown (mm)	Offset (mm)	Mat.	Method	DIA (mm)	Mat.	Finish	Pitch (mm)	Size Material	O.L.D.	Axle	Mat.	Max rotor DIA.	Brake mount
SF20	ZERON35-Boost-AIR RC DS 15QLC32-110 29"	2320	29"x2.4"	130/140 150/160	RC	AIR	570	51/44	Alloy	Forged	35	Alloy	Hard anodized, Black	145	1.5"to1-1/8" tapered(CTS), Alloy/ (OP) 1.8"to1-1/8" tapered(CTS), Alloy	ø15-110	15QLC32-110	Mg	203mm	Post 180 Direct
SF20	ZERON35-Boost-AIR RLR DS 15QLC32-110 29"	2320	29"x2.4"	130/140 150/160	RLR	AIR	570	51/44	Alloy	Forged	35	Alloy	Hard anodized, Black	145	1.5"to1-1/8" tapered(CTS), Alloy/ (OP) 1.8"to1-1/8" tapered(CTS), Alloy	ø15-110	15QLC32-110	Mg	203mm	Post 180 Direct
SF20	ZERON35-Boost-AIR LOR DS 15QLC32-110 29"	2323	29"x2.4"	130/140 150/160	LOR	AIR	570	51/44	Alloy	Forged	35	Alloy	Hard anodized, Black	145	1.5"to1-1/8" tapered(CTS), Alloy/ (OP) 1.8"to1-1/8" tapered(CTS), Alloy	ø15-110	15QLC32-110	Mg	203mm	Post 180 Direct
SF18	ZERON35-Boost RC DS 15QLC32-110 29"	2480	29"x2.4"	130/140 150	RC	COIL w/ Preload adjuster	570	51/44	Alloy	Forged	35	Alloy	Hard anodized, Black	145	1.5"to1-1/8" tapered(CTS), Alloy/ (OP) 1.8"to1-1/8" tapered(CTS), Alloy	ø15-110	15QLC32-110	Mg	203mm	Post 180 Direct
SF18	ZERON35-Boost RLR DS 15QLC32-110 29"	2480	29"x2.4"	130/140 150	RLR	COIL w/ Preload adjuster	570	51/44	Alloy	Forged	35	Alloy	Hard anodized, Black	145	1.5"to1-1/8" tapered(CTS), Alloy/ (OP) 1.8"to1-1/8" tapered(CTS), Alloy	ø15-110	15QLC32-110	Mg	203mm	Post 180 Direct
SF18	ZERON35-Boost LOR DS 15QLC32-110 29"	2483	29"x2.4"	130/140 150	LOR	COIL w/ Preload adjuster	570	51/44	Alloy	Forged	35	Alloy	Hard anodized, Black	145	1.5"to1-1/8" tapered(CTS), Alloy/ (OP) 1.8"to1-1/8" tapered(CTS), Alloy	ø15-110	15QLC32-110	Mg	203mm	Post 180 Direct
SF20	ZERON35-Boost-AIR RC DS 15QLC32-110 27.5"	2317	27.5"x2.8"	130/140 150/160	RC	AIR	555.5	51/44	Alloy	Forged	35	Alloy	Hard anodized, Black	145	1.5"to1-1/8" tapered(CTS), Alloy/ (OP) 1.8"to1-1/8" tapered(CTS), Alloy	ø15-110	15QLC32-110	Mg	203mm	Post 180 Direct
SF20	ZERON35-Boost-AIR RLR DS 15QLC32-110 27.5"	2317	27.5"x2.8"	130/140 150/160	RLR	AIR	555.5	51/44	Alloy	Forged	35	Alloy	Hard anodized, Black	145	1.5"to1-1/8" tapered(CTS), Alloy/ (OP) 1.8"to1-1/8" tapered(CTS), Alloy	ø15-110	15QLC32-110	Mg	203mm	Post 180 Direct
SF20	ZERON35-Boost-AIR LOR DS 15QLC32-110 27.5"	2320	27.5"x2.8"	130/140 150/160	LOR	AIR	555.5	51/44	Alloy	Forged	35	Alloy	Hard anodized, Black	145	1.5"to1-1/8" tapered(CTS), Alloy/ (OP) 1.8"to1-1/8" tapered(CTS), Alloy	ø15-110	15QLC32-110	Mg	203mm	Post 180 Direct
SF19	ZERON35-Boost RC DS 15QLC32-110 27.5"	2477	27.5"x2.8"	130/140 150	RC	COIL w/ Preload adjuster	555.5	51/44	Alloy	Forged	35	Alloy	Hard anodized, Black	145	1.5"to1-1/8" tapered(CTS), Alloy/ (OP) 1.8"to1-1/8" tapered(CTS), Alloy	ø15-110	15QLC32-110	Mg	203mm	Post 180 Direct
SF19	ZERON35-Boost RLR DS 15QLC32-110 27.5"	2477	27.5"x2.8"	130/140 150	RLR	COIL w/ Preload adjuster	555.5	51/44	Alloy	Forged	35	Alloy	Hard anodized, Black	145	1.5"to1-1/8" tapered(CTS), Alloy/ (OP) 1.8"to1-1/8" tapered(CTS), Alloy	ø15-110	15QLC32-110	Mg	203mm	Post 180 Direct
SF19	ZERON35-Boost LOR DS 15QLC32-110 27.5"	2480	27.5"x2.8"	130/140 150	LOR	COIL w/ Preload adjuster	555.5	51/44	Alloy	Forged	35	Alloy	Hard anodized, Black	145	1.5"to1-1/8" tapered(CTS), Alloy/ (OP) 1.8"to1-1/8" tapered(CTS), Alloy	ø15-110	15QLC32-110	Mg	203mm	Post 180 Direct

AXON WERX

CROSS COUNTRY

29"

27.5"

34 mm

32 mm

34 Werx Boost EQ
RLRC-PCS 29"



ENDURO / TRAIL / CROSS COUNTRY

SPECIFICATIONS

// 2022



MODEL YEAR	MODEL NAME	MAIN SPECIFICATIONS							CROWN		STANCHION				STEERER TUBE	AXLE		BOTTOM CASE / BRAKE		
		Weight (g) w/o axle	Wheel	Travel (mm)	Damper	Spring	Axle to crown (mm)	Offset (mm)	Mat.	Method	DIA (mm)	Mat.	Finish	Pitch (mm)	Size Material	O.L.D.	Axle	Mat.	Max rotor DIA.	Brake mount
SF20	AXON34-WERX-Boost EQ RLRC-PCS DS 15QLC2Ti-110 29"	1598	29"x2.4"	100 110 120	RLRC-PCS	AIR (EQ)	531	51	Carbon	Hollow	34	Alloy	Hard anodized, Black	142	1.5"to1-1/8" tapered(CTS), Carbon	ø15-110	15QLC2Ti-110	Mg	180mm	Post 160 Direct

AXON WERX

CROSS COUNTRY

29"

27.5"

34 mm

32 mm

Werx F RLRC-PCS 29"



MODEL YEAR	MODEL NAME	MAIN SPECIFICATIONS							CROWN		STANCHION				STEERER TUBE		AXLE		BOTTOM CASE / BRAKE		
		Weight (g) w/o axle	Wheel	Travel (mm)	Damper	Spring	Axle to crown (mm)	Offset (mm)	Mat.	Method	DIA (mm)	Mat.	Finish	Pitch (mm)	Size	Material	O.L.D.	Axle	Mat.	Max rotor DIA.	Brake mount
SF17	AXON-WERX-F RLRC-PCS DS 15QLC2Ti 29"	1486	29"	80/100	RLRC-PCS	AIR	508	46	Carbon	Hollow	32	Alloy	Hard anodized, Gold	130	1.5"to1-1/8" tapered(CTS), Carbon	ø15-100	15QLC2Ti	Carbon	180mm	Post 160 Direct	
SF17	AXON-WERX-F RLRC-PCS DS 15QLC2Ti 27.5"	1482	27.5"	80/100	RLRC-PCS	AIR	488	42	Carbon	Hollow	32	Alloy	Hard anodized, Gold	130	1.5"to1-1/8" tapered(CTS), Carbon	ø15-100	15QLC2Ti	Carbon	180mm	Post 160 Direct	
SF17	AXON-WERX RLRC-PCS DS 15QLC2Ti 29"	1570	29"	80/100	RLRC-PCS	AIR	508	46	Alloy	Hollow Forged	32	Alloy	Hard anodized, Gold	130	1-1/8"(TS), Alloy/(OP) 1.5"to1-1/8" tapered(CTS), Alloy	ø15-100	15QLC2Ti	Carbon	180mm	Post 160 Direct	
SF17	AXON-WERX RLRC-PCS DS 15QLC2Ti 27.5"	1564	27.5"	80/100	RLRC-PCS	AIR	488	42	Alloy	Hollow Forged	32	Alloy	Hard anodized, Gold	130	1-1/8"(TS), Alloy/(OP) 1.5"to1-1/8" tapered(CTS), Alloy	ø15-100	15QLC2Ti	Carbon	180mm	Post 160 Direct	

34 Elite Boost EQ
RLRC-PCS 29"

Elite RLRC-PCS 29"



MODEL YEAR	MODEL NAME	MAIN SPECIFICATIONS							CROWN		STANCHION			STEERER TUBE		AXLE		BOTTOM CASE / BRAKE		
		Weight (g) w/o axle	Wheel	Travel (mm)	Damper	Spring	Axle to crown (mm)	Offset (mm)	Mat.	Method	DIA (mm)	Mat.	Finish	Pitch (mm)	Size Material	O.L.D.	Axle	Mat.	Max rotor DIA.	Brake mount
SF20	AXON34-Elite-Boost EQ RLRC-PCS DS 15QLC2Ti-110 29"	1690	29"x2.4"	100/110/120	RLRC-PCS	AIR (EQ)	532.5	51/44	Alloy	Hollow Forged	34	Alloy	Hard anodized, Black	142	1.5"to1-1/8" tapered(CTS), Alloy	ø15-110	15QLC2Ti-110	Mg	180mm	Post 160 Direct
SF17	AXON-elite RLRC-PCS DS 15QLC2Ti 29"	1599	29"	80/100	RLRC-PCS	AIR	508	46	Alloy	Hollow Forged	32	Alloy	Hard anodized, Gold	130	1-1/8"(TS), Alloy/ (OP) 1.5"to1-1/8" tapered(CTS), Alloy	ø15-100	15QLC2Ti	Mg	180mm	Post 160 Direct
SF17	AXON-elite RLRC-PCS DS 15QLC2Ti 27.5"	1585	27.5"	80/100	RLRC-PCS	AIR	488	43	Alloy	Hollow Forged	32	Alloy	Hard anodized, Gold	130	1-1/8"(TS), Alloy/ (OP) 1.5"to1-1/8" tapered(CTS), Alloy	ø15-100	15QLC2Ti	Mg	180mm	Post 160 Direct
SF18	AXON34-Boost RLRC-PCS DS 15QLC2-110 29"	1900	29"x2.4"	100/120/130/140	RLRC-PCS	AIR	552	51/44	Alloy	Forged	34	Alloy	Hard anodized, Black	145	1.5"to1-1/8" tapered(CTS), Alloy	ø15-110	15QLC2-110	Mg	203mm	Post 180 Direct
SF18	AXON34-Boost LORC-PCS DS 15QLC2-110 29"	1900	29"x2.4"	100/120/130/140	LORC-PCS	AIR	552	51/44	Alloy	Forged	34	Alloy	Hard anodized, Black	145	1.5"to1-1/8" tapered(CTS), Alloy	ø15-110	15QLC2-110	Mg	203mm	Post 180 Direct
SF18	AXON34-Boost RLRC-PCS DS 15QLC2-110 27.5"	1895	27.5"x2.6"	100/120/130/140	RLRC-PCS	AIR	533	44	Alloy	Forged	34	Alloy	Hard anodized, Black	145	1.5"to1-1/8" tapered(CTS), Alloy	ø15-110	15QLC2-110	Mg	203mm	Post 180 Direct
SF18	AXON34-Boost LORC-PCS DS 15QLC2-110 27.5"	1895	27.5"x2.6"	100/120/130/140	LORC-PCS	AIR	533	44	Alloy	Forged	34	Alloy	Hard anodized, Black	145	1.5"to1-1/8" tapered(CTS), Alloy	ø15-110	15QLC2-110	Mg	203mm	Post 180 Direct
SF19	AXON32-Boost RLRC-DS 15QLC2-110 29"	1882	29"x2.4"	80/100/120	RLRC	AIR	514.5	46	Alloy	Hollow Forged	32	Alloy	Hard anodized, Black	133	1.5"to1-1/8" tapered(CTS), Alloy	ø15-110	15QLC2-110	Mg	180mm	Post 160 Direct
SF19	AXON32-Boost LORC-DS 15QLC2-110 29"	1882	29"x2.4"	80/100/120	LORC	AIR	514.5	46	Alloy	Hollow Forged	32	Alloy	Hard anodized, Black	133	1.5"to1-1/8" tapered(CTS), Alloy	ø15-110	15QLC2-110	Mg	180mm	Post 160 Direct
SF19	AXON32-Boost RLRC-DS 15QLC2-110 27.5"	1892	27.5"x2.6"	100/120	RLRC	AIR	518.5	42	Alloy	Hollow Forged	32	Alloy	Hard anodized, Black	133	1.5"to1-1/8" tapered(CTS), Alloy	ø15-110	15QLC2-110	Mg	180mm	Post 160 Direct
SF19	AXON32-Boost LORC-DS 15QLC2-110 27.5"	1892	27.5"x2.6"	100/120	LORC	AIR	518.5	42	Alloy	Hollow Forged	32	Alloy	Hard anodized, Black	133	1.5"to1-1/8" tapered(CTS), Alloy	ø15-110	15QLC2-110	Mg	180mm	Post 160 Direct

34 Boost LORC-PCS 29"



32 Boost LORC 29"



LORC 29"



MODEL YEAR	MODEL NAME	MAIN SPECIFICATIONS						CROWN		STANCHION			STEERER TUBE		AXLE		BOTTOM CASE / BRAKE			
		Weight (g) w/o axle	Wheel	Travel (mm)	Damper	Spring	Axle to crown (mm)	Offset (mm)	Mat.	Method	DIA (mm)	Mat.	Finish	Pitch (mm)	Size	Material	O.L.D.	Axle	Mat.	Max rotor DIA.
SF17	AXON RLRC DS 15QLC2 29"	1641	29"	80/100 120	RLRC	AIR	531	46	Alloy	Forged	32	Alloy	Hard anodized, Gold	130	1-1/8"(TS), Alloy/ (OP) 1.5"to1-1/8" tapered(CTS), Alloy	ø15-100	15QLC2/ (OP) 15QLC2Ti	Mg	180mm	Post 160 Direct
SF17	AXON LORC DS 15QLC2 29"	1628	29"	80/100 120	LORC	AIR	531	46	Alloy	Forged	32	Alloy	Hard anodized, Gold	130	1-1/8"(TS), Alloy/ (OP) 1.5"to1-1/8" tapered(CTS), Alloy	ø15-100	15QLC2/ (OP) 15QLC2Ti	Mg	180mm	Post 160 Direct
SF17	AXON RLR DS 15QLC32 29"	1683	29"	80/100 120	RLR	AIR	531	46	Alloy	Forged	32	Alloy	Hard anodized, Gold	130	1-1/8"(TS), Alloy/ (OP) 1.5"to1-1/8" tapered(CTS), Alloy	ø15-100	15QLC32	Mg	180mm	Post 160 Direct
SF17	AXON LOR DS 15QLC32 29"	1664	29"	80/100 120	LOR	AIR	531	46	Alloy	Forged	32	Alloy	Hard anodized, Gold	130	1-1/8"(TS), Alloy/ (OP) 1.5"to1-1/8" tapered(CTS), Alloy	ø15-100	15QLC32	Mg	180mm	Post 160 Direct
SF17	AXON RLRC DS 15QLC2 27.5"	1605	27.5"	100/120	RLRC	AIR	509	43	Alloy	Forged	32	Alloy	Hard anodized, Gold	130	1-1/8"(TS), Alloy/ (OP) 1.5"to1-1/8" tapered(CTS), Alloy	ø15-100	15QLC2/ (OP) 15QLC2Ti	Mg	180mm	Post 160 Direct
SF17	AXON LORC DS 15QLC2 27.5"	1598	27.5"	100/120	LORC	AIR	509	43	Alloy	Forged	32	Alloy	Hard anodized, Gold	130	1-1/8"(TS), Alloy/ (OP) 1.5"to1-1/8" tapered(CTS), Alloy	ø15-100	15QLC2/ (OP) 15QLC2Ti	Mg	180mm	Post 160 Direct
SF17	AXON RLR DS 15QLC32 27.5"	1649	27.5"	100/120	RLR	AIR	509	43	Alloy	Forged	32	Alloy	Hard anodized, Gold	130	1-1/8"(TS), Alloy/ (OP) 1.5"to1-1/8" tapered(CTS), Alloy	ø15-100	15QLC32	Mg	180mm	Post 160 Direct
SF17	AXON LOR DS 15QLC32 27.5"	1628	27.5"	100/120	LOR	AIR	509	43	Alloy	Forged	32	Alloy	Hard anodized, Gold	130	1-1/8"(TS), Alloy/ (OP) 1.5"to1-1/8" tapered(CTS), Alloy	ø15-100	15QLC32	Mg	180mm	Post 160 Direct

LOR 29"



TRAIL / CROSS COUNTRY

AXON // EPIXON

MODEL YEAR	MODEL NAME	MAIN SPECIFICATIONS							CROWN		STANCHION			STEERER TUBE	AXLE		BOTTOM CASE / BRAKE			
		Weight (g) w/o axle	Wheel	Travel (mm)	Damper	Spring	Axle to crown (mm)	Offset (mm)	Mat.	Method	DIA (mm)	Mat.	Finish	Pitch (mm)	Size Material	O.L.D.	Axle	Mat.	Max rotor DIA.	Brake mount
SF18	EPIXON-9 RLR DS 29"	1835	29"	100/120	RLR	AIR	531.5	46	Alloy	Forged	32	Alloy	Hard anodized, Black	130	1-1/8"(TS), Alloy/(OP) 1.5"to1-1/8" tapered(CTS), Alloy	9-100	9mm-Dropout	Mg	180mm	Post 160 Direct
SF18	EPIXON-9 LOR DS 29"	1830	29"	100/120	LOR	AIR	531.5	46	Alloy	Forged	32	Alloy	Hard anodized, Black	130	1-1/8"(TS), Alloy/(OP) 1.5"to1-1/8" tapered(CTS), Alloy	9-100	9mm-Dropout	Mg	180mm	Post 160 Direct
SF18	EPIXON-9 RLR DS 27.5"	1834	27.5"	100/120	RLR	AIR	514	42	Alloy	Forged	32	Alloy	Hard anodized, Black	130	1-1/8"(TS), Alloy/(OP) 1.5"to1-1/8" tapered(CTS), Alloy	9-100	9mm-Dropout	Mg	180mm	Post 160 Direct
SF18	EPIXON-9 LOR DS 27.5"	1829	27.5"	100/120	LOR	AIR	514	42	Alloy	Forged	32	Alloy	Hard anodized, Black	130	1-1/8"(TS), Alloy/(OP) 1.5"to1-1/8" tapered(CTS), Alloy	9-100	9mm-Dropout	Mg	180mm	Post 160 Direct
SF18	EPIXON-9 RLR DS 26"	1834	26"	100/120	RLR	AIR	501	40	Alloy	Forged	32	Alloy	Hard anodized, Black	130	1-1/8"(TS), Alloy/(OP) 1.5"to1-1/8" tapered(CTS), Alloy	9-100	9mm-Dropout	Mg	180mm	Post 160 Direct
SF18	EPIXON-9 LOR DS 26"	1829	26"	100/120	LOR	AIR	501	40	Alloy	Forged	32	Alloy	Hard anodized, Black	130	1-1/8"(TS), Alloy/(OP) 1.5"to1-1/8" tapered(CTS), Alloy	9-100	9mm-Dropout	Mg	180mm	Post 160 Direct

SPECIFICATIONS

// 2022

SUNTOUR

RAIDON



34 Boost LOR 29"



32 Boost LOR 27.5"

MODEL YEAR	MODEL NAME	MAIN SPECIFICATIONS					CROWN			STANCHION				STEERER TUBE	AXLE		BOTTOM CASE / BRAKE			
		Weight (g) w/o axle	Wheel	Travel (mm)	Damper	Spring	Axle to crown (mm)	Offset (mm)	Mat.	Method	DIA (mm)	Mat.	Finish	Pitch (mm)	Size Material	O.L.D.	Axle	Mat.	Max rotor DIA.	Brake mount
SF18	RAIDON34-Boost RLR DS 15QLC32-110 29"	2020	29"x2.4"	100/120 130/140	RLR	AIR	556.5	51/44	AC4C	-	34	Alloy	Hard anodized, Black	145	1.5"to1-1/8" tapered(CTS), Alloy	ø15-110	15QLC32-110	Mg	203mm	Post 180 Direct
SF18	RAIDON34-Boost LOR DS 15QLC32-110 29"	2016	29"x2.4"	100/120 130/140	LOR	AIR	556.5	51/44	AC4C	-	34	Alloy	Hard anodized, Black	145	1.5"to1-1/8" tapered(CTS), Alloy	ø15-110	15QLC32-110	Mg	203mm	Post 180 Direct
SF18	RAIDON34-Boost RLR DS 15QLC32-110 27.5"	2034	27.5"x2.6"	80/120 130/140	RLR	AIR	537.5	44	AC4C	-	34	Alloy	Hard anodized, Black	145	1.5"to1-1/8" tapered(CTS), Alloy	ø15-110	15QLC32-110	Mg	203mm	Post 180 Direct
SF18	RAIDON34-Boost LOR DS 15QLC32-110 27.5"	2033	27.5"x2.6"	80/120 130/140	LOR	AIR	533	44	AC4C	-	34	Alloy	Hard anodized, Black	145	1.5"to1-1/8" tapered(CTS), Alloy	ø15-110	15QLC32-110	Mg	203mm	Post 180 Direct
SF19	RAIDON32-Boost RLR DS 15QLC32-110 29"	2020	29"x2.4"	80/100 120	RLR	AIR	519	46	AC4C	-	32	Alloy	Hard anodized, Black	133	1.5"to1-1/8" tapered(CTS), Alloy	ø15-110	15QLC32-110	Mg	180mm	Post 160 Direct
SF19	RAIDON32-Boost LOR DS 15QLC32-110 29"	2020	29"x2.4"	80/100 120	LOR	AIR	519	46	AC4C	-	32	Alloy	Hard anodized, Black	133	1.5"to1-1/8" tapered(CTS), Alloy	ø15-110	15QLC32-110	Mg	180mm	Post 160 Direct
SF19	RAIDON32-Boost RLR DS 15QLC32-110 27.5"	2025	27.5"x2.6"	100/120	RLR	AIR	523	42	AC4C	-	32	Alloy	Hard anodized, Black	133	1.5"to1-1/8" tapered(CTS), Alloy	ø15-110	15QLC32-110	Mg	180mm	Post 160 Direct
SF19	RAIDON32-Boost LOR DS 15QLC32-110 27.5"	2019	27.5"x2.6"	100/120	LOR	AIR	523	42	AC4C	-	32	Alloy	Hard anodized, Black	133	1.5"to1-1/8" tapered(CTS), Alloy	ø15-110	15QLC32-110	Mg	180mm	Post 160 Direct

32-LT LOR 26"

XC LOR 29"



MODEL YEAR	MODEL NAME	MAIN SPECIFICATIONS							CROWN		STANCHION			STEERER TUBE		AXLE		BOTTOM CASE / BRAKE		
		Weight (g) w/o axle	Wheel	Travel (mm)	Damper	Spring	Axle to crown (mm)	Offset (mm)	Mat.	Method	DIA (mm)	Mat.	Finish	Pitch (mm)	Size Material	O.L.D.	Axle	Mat.	Max rotor DIA.	Brake mount
SF19	RAIDON32-LT RLR DS 15QLC32 26"	1967	26"x2.25"	100/120	RLR	AIR	499	40	AC4C	-	32	Alloy	Hard anodized, Black	130	1-1/8"(TS), Cr-Mo/(OP) 1.5"to 1-1/8" tapered(CTS), Alloy	ø15-100	15QLC32	Mg	180mm	Post 160 Direct
SF19	RAIDON32-LT LOR DS 15QLC32 26"	1963	26"x2.25"	100/120	LOR	AIR	499	40	AC4C	-	32	Alloy	Hard anodized, Black	130	1-1/8"(TS), Cr-Mo/(OP) 1.5"to 1-1/8" tapered(CTS), Alloy	ø15-100	15QLC32	Mg	180mm	Post 160 Direct
SF16	RAIDON-XC RLR DS 15QLC32 29"	2066	29"x2.25"	80/100	RLR	AIR	517	46	AC4C	-	32	Alloy	Hard anodized, Gold	130	1-1/8"(TS), Cr-Mo/(OP) 1.5"to 1-1/8" tapered(CTS), Alloy	ø15-100	15QLC32	Mg	180mm	Post 160 Direct
SF16	RAIDON-XC LOR DS 15QLC32 29"	2061	29"x2.25"	80/100	LOR	AIR	517	46	AC4C	-	32	Alloy	Hard anodized, Gold	130	1-1/8"(TS), Cr-Mo/(OP) 1.5"to 1-1/8" tapered(CTS), Alloy	ø15-100	15QLC32	Mg	180mm	Post 160 Direct
SF16	RAIDON-XC RLR DS 15QLC32 27.5"	2003	27.5"x2.25"	100/120	RLR	AIR	514	42	AC4C	-	32	Alloy	Hard anodized, Gold	130	1-1/8"(TS), Cr-Mo/(OP) 1.5"to 1-1/8" tapered(CTS), Alloy	ø15-100	15QLC32	Mg	180mm	Post 160 Direct
SF16	RAIDON-XC LOR DS 15QLC32 27.5"	1999	27.5"x2.25"	100/120	LOR	AIR	514	42	AC4C	-	32	Alloy	Hard anodized, Gold	130	1-1/8"(TS), Cr-Mo/(OP) 1.5"to 1-1/8" tapered(CTS), Alloy	ø15-100	15QLC32	Mg	180mm	Post 160 Direct
SF16	RAIDON-XC RLR DS 29"	2084	29"x2.25"	80/100	RLR	AIR	517	46	AC4C	-	32	Alloy	Hard anodized, Gold	130	1-1/8"(TS), Cr-Mo/(OP) 1.5"to 1-1/8" tapered(CTS), Alloy	9-100	9mm-Dropout	Mg	180mm	Post 160 Direct
SF16	RAIDON-XC LOR DS 29"	2067	29"x2.25"	80/100	LOR	AIR	517	46	AC4C	-	32	Alloy	Hard anodized, Gold	130	1-1/8"(TS), Cr-Mo/(OP) 1.5"to 1-1/8" tapered(CTS), Alloy	9-100	9mm-Dropout	Mg	180mm	Post 160 Direct
SF16	RAIDON-XC RLR DS 27.5"	2013	27.5"x2.25"	100/120	RLR	AIR	514	42	AC4C	-	32	Alloy	Hard anodized, Gold	130	1-1/8"(TS), Cr-Mo/(OP) 1.5"to 1-1/8" tapered(CTS), Alloy	9-100	9mm-Dropout	Mg	180mm	Post 160 Direct
SF16	RAIDON-XC LOR DS 27.5"	2021	27.5"x2.25"	100/120	LOR	AIR	514	42	AC4C	-	32	Alloy	Hard anodized, Gold	130	1-1/8"(TS), Cr-Mo/(OP) 1.5"to 1-1/8" tapered(CTS), Alloy	9-100	9mm-Dropout	Mg	180mm	Post 160 Direct
SF16	RAIDON-XC RLR DS 26"	1994	26"x2.25"	100/120	RLR	AIR	501	40	AC4C	-	32	Alloy	Hard anodized, Gold	130	1-1/8"(TS), Cr-Mo/(OP) 1.5"to 1-1/8" tapered(CTS), Alloy	9-100	9mm-Dropout	Mg	180mm	Post 160 Direct
SF16	RAIDON-XC LOR DS 26"	1972	26"x2.25"	100/120	LOR	AIR	501	40	AC4C	-	32	Alloy	Hard anodized, Gold	130	1-1/8"(TS), Cr-Mo/(OP) 1.5"to 1-1/8" tapered(CTS), Alloy	9-100	9mm-Dropout	Mg	180mm	Post 160 Direct



MODEL YEAR	MODEL NAME	MAIN SPECIFICATIONS							CROWN		STANCHION				STEERER TUBE	AXLE		BOTTOM CASE / BRAKE		
		Weight (g) w/o axle	Wheel	Travel (mm)	Damper	Spring	Axle to crown (mm)	Offset (mm)	Mat.	Method	DIA (mm)	Mat.	Finish	Pitch (mm)	Size Material	O.L.D.	Axle	Mat.	Max rotor DIA.	Brake mount
SF18	XCR34-AIR-Boost RLR DS 15QLC32-110 29"	2360	29"x2.4"	100/120 130/140	RLR	AIR	556.5	51/44	AC4C	-	34	STKM	Ni-plating/ Hard anodized, Black	145	1.5"to 1-1/8" tapered(CTS), Alloy/ (OP) 1.8"to 1-1/8" tapered(CTS), Alloy	ø15-110	15QLC32- 110	Mg	203mm	Post 180 Direct
SF18	XCR34-AIR-Boost LOR DS 15QLC32-110 29"	2339	29"x2.4"	100/120 130/140	LOR	AIR	556.5	51/44	AC4C	-	34	STKM	Ni-plating/ Hard anodized, Black	145	1.5"to 1-1/8" tapered(CTS), Alloy/ (OP) 1.8"to 1-1/8" tapered(CTS), Alloy	ø15-110	15QLC32- 110	Mg	203mm	Post 180 Direct
SF18	XCR34-COIL-Boost RLR DS 15QLC32-110 29"	2386	29"x2.4"	100/120 130	RLR	COIL w/ Preload adjuster	556.5	51/44	AC4C	-	34	STKM	Ni-plating/ Hard anodized, Black	145	1.5"to 1-1/8" tapered(CTS), Alloy/ (OP) 1.8"to 1-1/8" tapered(CTS), Alloy	ø15-110	15QLC32- 110	Mg	203mm	Post 180 Direct
SF18	XCR34-COIL-Boost LOR DS 15QLC32-110 29"	2381	29"x2.4"	100/120 130	LOR	COIL w/ Preload adjuster	556.5	51/44	AC4C	-	34	STKM	Ni-plating/ Hard anodized, Black	145	1.5"to 1-1/8" tapered(CTS), Alloy/ (OP) 1.8"to 1-1/8" tapered(CTS), Alloy	ø15-110	15QLC32- 110	Mg	203mm	Post 180 Direct
SF18	XCR34-COIL-Boost RL DS 15QLC32-110 29"	2385	29"x2.4"	100/120 130	RL	COIL w/ Preload adjuster	556.5	51/44	AC4C	-	34	STKM	Ni-plating/ Hard anodized, Black	145	1.5"to 1-1/8" tapered(CTS), Alloy/ (OP) 1.8"to 1-1/8" tapered(CTS), Alloy	ø15-110	15QLC32- 110	Mg	203mm	Post 180 Direct
SF18	XCR34-COIL-Boost LO DS 15QLC32-110 29"	2380	29"x2.4"	100/120 130	LO	COIL w/ Preload adjuster	556.5	51/44	AC4C	-	34	STKM	Ni-plating/ Hard anodized, Black	145	1.5"to 1-1/8" tapered(CTS), Alloy/ (OP) 1.8"to 1-1/8" tapered(CTS), Alloy	ø15-110	15QLC32- 110	Mg	203mm	Post 180 Direct
SF18	XCR34-AIR-Boost RLR DS 15QLC32-110 27.5"	2340	27.5"x2.6"	100/120 130/140	RLR	AIR	537.5	44	AC4C	-	34	STKM	Ni-plating/ Hard anodized, Black	145	1.5"to 1-1/8" tapered(CTS), Alloy/ (OP) 1.8"to 1-1/8" tapered(CTS), Alloy	ø15-110	15QLC32- 110	Mg	203mm	Post 180 Direct
SF18	XCR34-AIR-Boost LOR DS 15QLC32-110 27.5"	2335	27.5"x2.6"	100/120 130/140	LOR	AIR	537.5	44	AC4C	-	34	STKM	Ni-plating/ Hard anodized, Black	145	1.5"to 1-1/8" tapered(CTS), Alloy/ (OP) 1.8"to 1-1/8" tapered(CTS), Alloy	ø15-110	15QLC32- 110	Mg	203mm	Post 180 Direct
SF18	XCR34-COIL-Boost RLR DS 15QLC32-110 27.5"	2378	27.5"x2.6"	100/120 130	RLR	COIL w/ Preload adjuster	537.5	44	AC4C	-	34	STKM	Ni-plating/ Hard anodized, Black	145	1.5"to 1-1/8" tapered(CTS), Alloy/ (OP) 1.8"to 1-1/8" tapered(CTS), Alloy	ø15-110	15QLC32- 110	Mg	203mm	Post 180 Direct
SF18	XCR34-COIL-Boost LOR DS 15QLC32-110 27.5"	2373	27.5"x2.6"	100/120 130	LOR	COIL w/ Preload adjuster	537.5	44	AC4C	-	34	STKM	Ni-plating/ Hard anodized, Black	145	1.5"to 1-1/8" tapered(CTS), Alloy/ (OP) 1.8"to 1-1/8" tapered(CTS), Alloy	ø15-110	15QLC32- 110	Mg	203mm	Post 180 Direct
SF18	XCR34-COIL-Boost RL DS 15QLC32-110 27.5"	2375	27.5"x2.6"	100/120 130	RL	COIL w/ Preload adjuster	537.5	44	AC4C	-	34	STKM	Ni-plating/ Hard anodized, Black	145	1.5"to 1-1/8" tapered(CTS), Alloy/ (OP) 1.8"to 1-1/8" tapered(CTS), Alloy	ø15-110	15QLC32- 110	Mg	203mm	Post 180 Direct
SF18	XCR34-COIL-Boost LO DS 15QLC32-110 27.5"	2372	27.5"x2.6"	100/120 130	LO	COIL w/ Preload adjuster	537.5	44	AC4C	-	34	STKM	Ni-plating/ Hard anodized, Black	145	1.5"to 1-1/8" tapered(CTS), Alloy/ (OP) 1.8"to 1-1/8" tapered(CTS), Alloy	ø15-110	15QLC32- 110	Mg	203mm	Post 180 Direct



CROSS COUNTRY

XCR

MODEL YEAR	MODEL NAME	MAIN SPECIFICATIONS							CROWN		STANCHION		STEERER TUBE		AXLE		BOTTOM CASE / BRAKE			
		Weight (g) w/o axle	Wheel	Travel (mm)	Damper	Spring	Axle to crown (mm)	Offset (mm)	Mat.	Method	DIA (mm)	Mat.	Finish	Pitch (mm)	Size Material	O.L.D.	Axle	Mat.	Max rotor DIA.	Brake mount
SF19	XCR32-Boost-AIR RLR DS 15QLC32-110 29"	2320	29"x2.4"	80/100 120	RLR	AIR	539	46	AC4C	-	32	STKM	Ni-plating/ Hard anodized, Black	133	1.5"to1-1/8" tapered(CTS), Alloy	ø15-110	15QLC32-110	Mg	180mm	Post 160 Direct
SF19	XCR32-Boost-AIR LOR DS 15QLC32-110 29"	2317	29"x2.4"	80/100 120	LOR	AIR	539	46	AC4C	-	32	STKM	Ni-plating/ Hard anodized, Black	133	1.5"to1-1/8" tapered(CTS), Alloy	ø15-110	15QLC32-110	Mg	180mm	Post 160 Direct
SF19	XCR32-Boost-COIL RLR DS 15QLC32-110 29"	2358	29"x2.4"	80/100 120	RLR	COIL w/ Preload adjuster	539	46	AC4C	-	32	STKM	Ni-plating/ Hard anodized, Black	133	1.5"to1-1/8" tapered(CTS), Alloy	ø15-110	15QLC32-110	Mg	180mm	Post 160 Direct
SF19	XCR32-Boost-COIL LOR DS 15QLC32-110 29"	2354	29"x2.4"	80/100 120	LOR	COIL w/ Preload adjuster	539	46	AC4C	-	32	STKM	Ni-plating/ Hard anodized, Black	133	1.5"to1-1/8" tapered(CTS), Alloy	ø15-110	15QLC32-110	Mg	180mm	Post 160 Direct
SF19	XCR32-Boost-COIL RL DS 15QLC32-110 29"	2357	29"x2.4"	80/100 120	RL	COIL w/ Preload adjuster	539	46	AC4C	-	32	STKM	Ni-plating/ Hard anodized, Black	133	1.5"to1-1/8" tapered(CTS), Alloy	ø15-110	15QLC32-110	Mg	180mm	Post 160 Direct
SF19	XCR32-Boost-COIL LO DS 15QLC32-110 29"	2353	29"x2.4"	80/100 120	LO	COIL w/ Preload adjuster	539	46	AC4C	-	32	STKM	Ni-plating/ Hard anodized, Black	133	1.5"to1-1/8" tapered(CTS), Alloy	ø15-110	15QLC32-110	Mg	180mm	Post 160 Direct
SF19	XCR32-Boost-AIR RLR DS 15QLC32-110 27.5"	2318	27.5"x2.6"	100/120	RLR	AIR	523	42	AC4C	-	32	STKM	Ni-plating/ Hard anodized, Black	133	1.5"to1-1/8" tapered(CTS), Alloy	ø15-110	15QLC32-110	Mg	180mm	Post 160 Direct
SF19	XCR32-Boost-AIR LOR DS 15QLC32-110 27.5"	2315	27.5"x2.6"	100/120	LOR	AIR	523	42	AC4C	-	32	STKM	Ni-plating/ Hard anodized, Black	133	1.5"to1-1/8" tapered(CTS), Alloy	ø15-110	15QLC32-110	Mg	180mm	Post 160 Direct
SF19	XCR32-Boost-COIL RLR DS 15QLC32-110 27.5"	2357	27.5"x2.6"	100/120	RLR	COIL w/ Preload adjuster	523	42	AC4C	-	32	STKM	Ni-plating/ Hard anodized, Black	133	1.5"to1-1/8" tapered(CTS), Alloy	ø15-110	15QLC32-110	Mg	180mm	Post 160 Direct
SF19	XCR32-Boost-COIL LOR DS 15QLC32-110 27.5"	2353	27.5"x2.6"	100/120	LOR	COIL w/ Preload adjuster	523	42	AC4C	-	32	STKM	Ni-plating/ Hard anodized, Black	133	1.5"to1-1/8" tapered(CTS), Alloy	ø15-110	15QLC32-110	Mg	180mm	Post 160 Direct
SF19	XCR32-Boost-COIL RL DS 15QLC32-110 27.5"	2356	27.5"x2.6"	100/120	RL	COIL w/ Preload adjuster	523	42	AC4C	-	32	STKM	Ni-plating/ Hard anodized, Black	133	1.5"to1-1/8" tapered(CTS), Alloy	ø15-110	15QLC32-110	Mg	180mm	Post 160 Direct
SF19	XCR32-Boost-COIL LO DS 15QLC32-110 27.5"	2352	27.5"x2.6"	100/120	LO	COIL w/ Preload adjuster	523	42	AC4C	-	32	STKM	Ni-plating/ Hard anodized, Black	133	1.5"to1-1/8" tapered(CTS), Alloy	ø15-110	15QLC32-110	Mg	180mm	Post 160 Direct

SPECIFICATIONS

// 2022

SF SQUIDOR



MODEL YEAR	MODEL NAME	MAIN SPECIFICATIONS							CROWN		STANCHION				STEERER TUBE		AXLE		BOTTOM CASE / BRAKE		
		Weight (g) w/o axle	Wheel	Travel (mm)	Damper	Spring	Axle to crown (mm)	Offset (mm)	Mat.	Method	DIA (mm)	Mat.	Finish	Pitch (mm)	Size	Material	O.L.D.	Axle	Mat.	Max rotor DIA.	Brake mount
SF15	XCR-AIR RLR DS 15QLC32 29"	2481	29"	80 100	RLR	AIR	518	46	AC4C	-	32	STKM	Ni-plating/ Hard anodized, Black	130	1-1/8"(TS), STKM/ (OP) 1.5"to1-1/8" tapered(CTS), Alloy	ø15-100	15QLC32	Mg	180mm	Post 160 Direct	
SF15	XCR-AIR LOR DS 15QLC32 29"	2461	29"	80 100	LOR	AIR	518	46	AC4C	-	32	STKM	Ni-plating/ Hard anodized, Black	130	1-1/8"(TS), STKM/ (OP) 1.5"to1-1/8" tapered(CTS), Alloy	ø15-100	15QLC32	Mg	180mm	Post 160 Direct	
SF14	XCR-COIL-RLR DS 29"	2529	29"	80 100	RLR	COIL w/ Preload adjuster	518	46	AC4C	-	32	STKM	Ni-plating/ Hard anodized, Black	130	1-1/8"(TS), STKM/ (OP) 1.5"to1-1/8" tapered(CTS), Alloy	9-100	9mm- Dropout	Mg	180mm	Post 160 Direct	
SF14	XCR-COIL-LOR DS 29"	2509	29"	80 100	LOR	COIL w/ Preload adjuster	518	46	AC4C	-	32	STKM	Ni-plating/ Hard anodized, Black	130	1-1/8"(TS), STKM/ (OP) 1.5"to1-1/8" tapered(CTS), Alloy	9-100	9mm- Dropout	Mg	180mm	Post 160 Direct	
SF14	XCR-COIL-RL DS 29"	2502	29"	80 100	RL	COIL w/ Preload adjuster	518	46	AC4C	-	32	STKM	Ni-plating/ Hard anodized, Black	130	1-1/8"(TS), STKM/ (OP) 1.5"to1-1/8" tapered(CTS), Alloy	9-100	9mm- Dropout	Mg	180mm	Post 160 Direct	
SF14	XCR-COIL-LO DS 29"	2484	29"	80 100	LO	COIL w/ Preload adjuster	518	46	AC4C	-	32	STKM	Ni-plating/ Hard anodized, Black	130	1-1/8"(TS), STKM/ (OP) 1.5"to1-1/8" tapered(CTS), Alloy	9-100	9mm- Dropout	Mg	180mm	Post 160 Direct	
SF15	XCR32-COIL RLR DS 15QLC32 29"	2529	29"	80 100	RLR	COIL w/ Preload adjuster	518	46	AC4C	-	32	STKM	Ni-plating/ Hard anodized, Black	130	1-1/8"(TS), STKM/ (OP) 1.5"to1-1/8" tapered(CTS), Alloy	ø15-100	15QLC32	Mg	180mm	Post 160 Direct	
SF15	XCR32-COIL LOR DS 15QLC32 29"	2509	29"	80 100	LOR	COIL w/ Preload adjuster	518	46	AC4C	-	32	STKM	Ni-plating/ Hard anodized, Black	130	1-1/8"(TS), STKM/ (OP) 1.5"to1-1/8" tapered(CTS), Alloy	ø15-100	15QLC32	Mg	180mm	Post 160 Direct	
SF15	XCR32-COIL RL DS 15QLC32 29"	2502	29"	80 100	RL	COIL w/ Preload adjuster	518	46	AC4C	-	32	STKM	Ni-plating/ Hard anodized, Black	130	1-1/8"(TS), STKM/ (OP) 1.5"to1-1/8" tapered(CTS), Alloy	ø15-100	15QLC32	Mg	180mm	Post 160 Direct	
SF15	XCR32-COIL LO DS 15QLC32 29"	2484	29"	80 100	LO	COIL w/ Preload adjuster	518	46	AC4C	-	32	STKM	Ni-plating/ Hard anodized, Black	130	1-1/8"(TS), STKM/ (OP) 1.5"to1-1/8" tapered(CTS), Alloy	ø15-100	15QLC32	Mg	180mm	Post 160 Direct	

XCR-AIR LOR 26"



CROSS COUNTRY
XCR

		MAIN SPECIFICATIONS							CROWN		STANCHION			STEERER TUBE		AXLE		BOTTOM CASE / BRAKE		
MODEL YEAR	MODEL NAME	Weight (g) w/o axle	Wheel	Travel (mm)	Damper	Spring	Axle to crown (mm)	Offset (mm)	Mat.	Method	DIA (mm)	Mat.	Finish	Pitch (mm)	Size Material	O.L.D.	Axle	Mat.	Max rotor DIA.	Brake mount
SF14	XCR-AIR RLR DS 29"	2473	29"	80 100	RLR	AIR	518	46	AC4C	-	32	STKM	Ni-plating/ Hard anodized, Black	130	1-1/8"(TS), STKM/ (OP) 1.5"to1-1/8" tapered(CTS), Alloy	9-100	9mm- Dropout	Mg	180mm	Post 160 Direct
SF14	XCR-AIR LOR DS 29"	2456	29"	80 100	LOR	AIR	518	46	AC4C	-	32	STKM	Ni-plating/ Hard anodized, Black	130	1-1/8"(TS), STKM/ (OP) 1.5"to1-1/8" tapered(CTS), Alloy	9-100	9mm- Dropout	Mg	180mm	Post 160 Direct
SF15	XCR-AIR RLR DS 15QLC32 27.5"	2416	27.5"	100 120	RLR	AIR	516	42	AC4C	-	32	STKM	Ni-plating/ Hard anodized, Black	130	1-1/8"(TS), STKM/ (OP) 1.5"to1-1/8" tapered(CTS), Alloy	ø15-100	15QLC32	Mg	180mm	Post 160 Direct
SF15	XCR-AIR LOR DS 15QLC32 27.5"	2426	27.5"	100 120	LOR	AIR	516	42	AC4C	-	32	STKM	Ni-plating/ Hard anodized, Black	130	1-1/8"(TS), STKM/ (OP) 1.5"to1-1/8" tapered(CTS), Alloy	ø15-100	15QLC32	Mg	180mm	Post 160 Direct
SF14	XCR-COIL-RLR DS 27.5"	2510	27.5"	100 120	RLR	COIL w/ Preload adjuster	516	42	AC4C	-	32	STKM	Ni-plating/ Hard anodized, Black	130	1-1/8"(TS), STKM/ (OP) 1.5"to1-1/8" tapered(CTS), Alloy	9-100	9mm- Dropout	Mg	180mm	Post 160 Direct
SF14	XCR-COIL-LOR DS 27.5"	2500	27.5"	100 120	LOR	COIL w/ Preload adjuster	516	42	AC4C	-	32	STKM	Ni-plating/ Hard anodized, Black	130	1-1/8"(TS), STKM/ (OP) 1.5"to1-1/8" tapered(CTS), Alloy	9-100	9mm- Dropout	Mg	180mm	Post 160 Direct
SF14	XCR-COIL-RL DS 27.5"	2479	27.5"	100 120	RL	COIL w/ Preload adjuster	516	42	AC4C	-	32	STKM	Ni-plating/ Hard anodized, Black	130	1-1/8"(TS), STKM/ (OP) 1.5"to1-1/8" tapered(CTS), Alloy	9-100	9mm- Dropout	Mg	180mm	Post 160 Direct
SF14	XCR-COIL-LO DS 27.5"	2466	27.5"	100 120	LO	COIL w/ Preload adjuster	516	42	AC4C	-	32	STKM	Ni-plating/ Hard anodized, Black	130	1-1/8"(TS), STKM/ (OP) 1.5"to1-1/8" tapered(CTS), Alloy	9-100	9mm- Dropout	Mg	180mm	Post 160 Direct
SF15	XCR32-COIL RLR DS 15QLC32 27.5"	2520	27.5"	100 120	RLR	COIL w/ Preload adjuster	516	42	AC4C	-	32	STKM	Ni-plating/ Hard anodized, Black	130	1-1/8"(TS), STKM/ (OP) 1.5"to1-1/8" tapered(CTS), Alloy	ø15-100	15QLC32	Mg	180mm	Post 160 Direct
SF15	XCR32-COIL LOR DS 15QLC32 27.5"	2519	27.5"	100 120	LOR	COIL w/ Preload adjuster	516	42	AC4C	-	32	STKM	Ni-plating/ Hard anodized, Black	130	1-1/8"(TS), STKM/ (OP) 1.5"to1-1/8" tapered(CTS), Alloy	ø15-100	15QLC32	Mg	180mm	Post 160 Direct
SF15	XCR32-COIL RL DS 15QLC32 27.5"	2498	27.5"	100 120	RL	COIL w/ Preload adjuster	516	42	AC4C	-	32	STKM	Ni-plating/ Hard anodized, Black	130	1-1/8"(TS), STKM/ (OP) 1.5"to1-1/8" tapered(CTS), Alloy	ø15-100	15QLC32	Mg	180mm	Post 160 Direct
SF15	XCR32-COIL LO DS 15QLC32 27.5"	2485	27.5"	100 120	LO	COIL w/ Preload adjuster	516	42	AC4C	-	32	STKM	Ni-plating/ Hard anodized, Black	130	1-1/8"(TS), STKM/ (OP) 1.5"to1-1/8" tapered(CTS), Alloy	ø15-100	15QLC32	Mg	180mm	Post 160 Direct

SPECIFICATIONS

// 2022





MODEL YEAR	MODEL NAME	MAIN SPECIFICATIONS							CROWN		STANCHION				STEERER TUBE		AXLE			BOTTOM CASE / BRAKE	
		Weight (g) w/o axle	Wheel	Travel (mm)	Damper	Spring	Axle to crown (mm)	Offset (mm)	Mat.	Method	DIA (mm)	Mat.	Finish	Pitch (mm)	Size Material	O.L.D.	Axle	Mat.	Max rotor DIA.	Brake mount	
SF14	XCR-AIR RLR DS 27.5"	2408	27.5"	100 120	RLR	AIR	516	42	AC4C	-	32	STKM	Ni-plating/ Hard anodized, Black	130	1-1/8"(TS), STKM/ (OP) 1.5"to1-1/8" tapered(CTS), Alloy	9-100	9mm- Dropout	Mg	180mm	Post 160 Direct	
SF14	XCR-AIR LOR DS 27.5"	2418	27.5"	100 120	LOR	AIR	516	42	AC4C	-	32	STKM	Ni-plating/ Hard anodized, Black	130	1-1/8"(TS), STKM/ (OP) 1.5"to1-1/8" tapered(CTS), Alloy	9-100	9mm- Dropout	Mg	180mm	Post 160 Direct	
SF19	XCR32-AIR-LT RLR DS 15QLC32 26"	-	26"x2.25"	80 100	RLR	AIR	482	40	AC4C	-	32	STKM	Ni-plating/ Hard anodized, Black	130	1-1/8"(TS), STKM/ (OP) 1.5"to1-1/8" tapered(CTS), Alloy	ø15-100	15QLC32	Mg	180mm	Post 160 Direct	
SF19	XCR32-AIR-LT LOR DS 15QLC32 26"	-	26"x2.25"	80 100	LOR	AIR	482	40	AC4C	-	32	STKM	Ni-plating/ Hard anodized, Black	130	1-1/8"(TS), STKM/ (OP) 1.5"to1-1/8" tapered(CTS), Alloy	ø15-100	15QLC32	Mg	180mm	Post 160 Direct	
SF19	XCR32-COIL-LT RLR DS 15QLC32 26"	-	26"x2.25"	80 100	RLR	COIL w/ Preload adjuster	483	40	AC4C	-	32	STKM	Ni-plating/ Hard anodized, Black	130	1-1/8"(TS), STKM/ (OP) 1.5"to1-1/8" tapered(CTS), Alloy	ø15-100	15QLC32	Mg	180mm	Post 160 Direct	
SF19	XCR32-COIL-LT LOR DS 15QLC32 26"	-	26"x2.25"	80 100	LOR	COIL w/ Preload adjuster	483	40	AC4C	-	32	STKM	Ni-plating/ Hard anodized, Black	130	1-1/8"(TS), STKM/ (OP) 1.5"to1-1/8" tapered(CTS), Alloy	ø15-100	15QLC32	Mg	180mm	Post 160 Direct	



MODEL YEAR	MODEL NAME	MAIN SPECIFICATIONS							CROWN		STANCHION			STEERER TUBE		AXLE		BOTTOM CASE / BRAKE		
		Weight (g) w/o axle	Wheel	Travel (mm)	Damper	Spring	Axle to crown (mm)	Offset (mm)	Mat.	Method	DIA (mm)	Mat.	Finish	Pitch (mm)	Size Material	O.L.D.	Axle	Mat.	Max rotor DIA.	Brake mount
SF14	XCR-AIR RLR DS 26"	2361	26"	100 120	RLR	AIR	503	40	AC4C	-	32	STKM	Ni-plating/ Hard anodized, Black	130	1-1/8"(TS), STKM/ (OP) 1.5"to1-1/8" tapered(CTS), Alloy	9-100	9mm- Dropout	Mg	180mm	Post 160 Direct
SF14	XCR-AIR LOR DS 26"	2383	26"	100 120	LOR	AIR	503	40	AC4C	-	32	STKM	Ni-plating/ Hard anodized, Black	130	1-1/8"(TS), STKM/ (OP) 1.5"to1-1/8" tapered(CTS), Alloy	9-100	9mm- Dropout	Mg	180mm	Post 160 Direct
SF14	XCR32-COIL RLR DS 26"	2482	26"	100 120	RLR	COIL w/ Preload adjuster	503	40	AC4C	-	32	STKM	Ni-plating/ Hard anodized, Black	130	1-1/8"(TS), STKM/ (OP) 1.5"to1-1/8" tapered(CTS), Alloy	9-100	9mm- Dropout	Mg	180mm	Post 160 Direct
SF14	XCR32-COIL LOR DS 26"	2477	26"	100 120	LOR	COIL w/ Preload adjuster	503	40	AC4C	-	32	STKM	Ni-plating/ Hard anodized, Black	130	1-1/8"(TS), STKM/ (OP) 1.5"to1-1/8" tapered(CTS), Alloy	9-100	9mm- Dropout	Mg	180mm	Post 160 Direct
SF14	XCR32-COIL RL DS 26"	2449	26"	100 120	RL	COIL w/ Preload adjuster	503	40	AC4C	-	32	STKM	Ni-plating/ Hard anodized, Black	130	1-1/8"(TS), STKM/ (OP) 1.5"to1-1/8" tapered(CTS), Alloy	9-100	9mm- Dropout	Mg	180mm	Post 160 Direct
SF14	XCR32-COIL LO DS 26"	2427	26"	100 120	LO	COIL w/ Preload adjuster	503	40	AC4C	-	32	STKM	Ni-plating/ Hard anodized, Black	130	1-1/8"(TS), STKM/ (OP) 1.5"to1-1/8" tapered(CTS), Alloy	9-100	9mm- Dropout	Mg	180mm	Post 160 Direct
SF16	XCR-AIR LO DS 24"	1832	24"	63 80	LO	AIR	432	40	AC4C	-	28	STKM	Ni-plating/ Hard anodized, Black	126	1-1/8"(TS), Alloy	9-100	9mm- Dropout	Mg	160mm	Post 160 Direct
SF16	XCR-COIL LO DS 24"	1910	24"	63 80	LO	COIL w/ Preload adjuster	432	40	AC4C	-	28	STKM	Ni-plating/ Hard anodized, Black	126	1-1/8"(TS), STKM/ (OP) 1-1/8"(TS), Alloy	9-100	9mm- Dropout	Mg	160mm	Post 160 Direct

ATB version available with long fender mount - please also see page 92

32-ATB LO 29"



MODEL YEAR	MODEL NAME	MAIN SPECIFICATIONS							CROWN			STANCHION		STEERER TUBE	AXLE		BOTTOM CASE / BRAKE					
		Weight (g) w/o axle	Wheel	Travel (mm)	Damper	Spring	Axle to crown (mm)	Offset (mm)	Mat.	Method	DIA (mm)	Mat.	Finish		Pitch (mm)	Size Material	O.L.D.	Axle	Mat.	Max rotor DIA.	Brake mount	Note
SF21	XCR32-ATB DS RLR 29"	-	29"x2.4"	80/100	RLR	COIL w/ Preload adjuster	524	44	AC4C	-	32	STKM	Ni-plating/ Hard anodized, Black	130	1.5"to1-1/8" tapered(CTS), STKM/ (OP) 1.5"to1-1/8"	9-100	9mm-Dropout	Mg	180mm	Post 160 Direct	with lamp mount*	with long fender mount
SF21	XCR32-ATB LOR DS 29"	-	29"x2.4"	80/100	LOR	COIL w/ Preload adjuster	524	44	AC4C	-	32	STKM	Ni-plating/ Hard anodized, Black	130	1.5"to1-1/8" tapered(CTS), STKM/ (OP) 1.5"to1-1/8"	9-100	9mm-Dropout	Mg	180mm	Post 160 Direct	with lamp mount*	with long fender mount
SF21	XCR32-ATB DS RL 29"	-	29"x2.4"	80/100	RL	COIL w/ Preload adjuster	524	44	AC4C	-	32	STKM	Ni-plating/ Hard anodized, Black	130	1.5"to1-1/8" tapered(CTS), STKM/ (OP) 1.5"to1-1/8"	9-100	9mm-Dropout	Mg	180mm	Post 160 Direct	with lamp mount*	with long fender mount
SF21	XCR32-ATB DS LO 29"	-	29"x2.4"	80/100	LO	COIL w/ Preload adjuster	524	44	AC4C	-	32	STKM	Ni-plating/ Hard anodized, Black	130	1.5"to1-1/8" tapered(CTS), STKM/ (OP) 1.5"to1-1/8"	9-100	9mm-Dropout	Mg	180mm	Post 160 Direct	with lamp mount*	with long fender mount
SF21	XCR32-ATB DS RLR 27.5"	-	27.5"x2.4"	80/100	RLR	COIL w/ Preload adjuster	504	44	AC4C	-	32	STKM	Ni-plating/ Hard anodized, Black	130	1.5"to1-1/8" tapered(CTS), STKM/ (OP) 1.5"to1-1/8"	9-100	9mm-Dropout	Mg	180mm	Post 160 Direct	with lamp mount*	with long fender mount
SF21	XCR32-ATB DS LOR 27.5"	-	27.5"x2.4"	80/100	LOR	COIL w/ Preload adjuster	504	44	AC4C	-	32	STKM	Ni-plating/ Hard anodized, Black	130	1.5"to1-1/8" tapered(CTS), STKM/ (OP) 1.5"to1-1/8"	9-100	9mm-Dropout	Mg	180mm	Post 160 Direct	with lamp mount*	with long fender mount
SF21	XCR32-ATB DS RL 27.5"	-	27.5"x2.4"	80/100	RL	COIL w/ Preload adjuster	504	44	AC4C	-	32	STKM	Ni-plating/ Hard anodized, Black	130	1.5"to1-1/8" tapered(CTS), STKM/ (OP) 1.5"to1-1/8"	9-100	9mm-Dropout	Mg	180mm	Post 160 Direct	with lamp mount*	with long fender mount
SF21	XCR32-ATB DS LO 27.5"	-	27.5"x2.4"	80/100	LO	COIL w/ Preload adjuster	504	44	AC4C	-	32	STKM	Ni-plating/ Hard anodized, Black	130	1.5"to1-1/8" tapered(CTS), STKM/ (OP) 1.5"to1-1/8"	9-100	9mm-Dropout	Mg	180mm	Post 160 Direct	with lamp mount*	with long fender mount

*Front face on fork crown

ATB version available with long fender mount - please also see page 92

32-ATB LO 29"



CROSS COUNTRY / CASUAL MTB

XCR // XCM

MODEL YEAR	MODEL NAME	MAIN SPECIFICATIONS							CROWN		STANCHION			STEERER TUBE	AXLE		BOTTOM CASE / BRAKE					
		Weight (g) w/o axle	Wheel	Travel (mm)	Damper	Spring	Axle to crown (mm)	Offset (mm)	Mat.	Method	DIA (mm)	Mat.	Finish	Pitch (mm)	Size Material	O.L.D.	Axle	Mat.	Max rotor DIA.	Brake mount	Note	
SF21	XCM32-ATB DS RL 29"	-	29"x2.4"	80 100 120	RL	COIL w/ Preload adjuster	523	44	AC4C	-	32	STKM	Cr-plating	130	1.5"to1-1/8" tapered(CTS), STKM	9-100	9mm-Dropout	Al	180mm	Post 160 Direct	with lamp mount*	with long fender mount
SF21	XCM32-ATB DS LO 29"	-	29"x2.4"	80 100 120	LO	COIL w/ Preload adjuster	523	44	AC4C	-	32	STKM	Cr-plating	130	1.5"to1-1/8" tapered(CTS), STKM	9-100	9mm-Dropout	Al	180mm	Post 160 Direct	with lamp mount*	with long fender mount
SF21	XCM32-ATB DS NLO 29"	-	29"x2.4"	80 100 120	HLO	COIL w/ Preload adjuster	523	44	AC4C	-	32	STKM	Cr-plating	130	1.5"to1-1/8" tapered(CTS), STKM	9-100	9mm-Dropout	Al	180mm	Post 160 Direct	with lamp mount*	with long fender mount
SF21	XCM32-ATB DS RL 27.5"	-	27.5"x2.4"	80 100 120	RL	COIL w/ Preload adjuster	503	44	AC4C	-	32	STKM	Cr-plating	130	1.5"to1-1/8" tapered(CTS), STKM	9-100	9mm-Dropout	Al	180mm	Post 160 Direct	with lamp mount*	with long fender mount
SF21	XCM32-ATB DS LO 27.5"	-	27.5"x2.4"	80 100 120	LO	COIL w/ Preload adjuster	503	44	AC4C	-	32	STKM	Cr-plating	130	1.5"to1-1/8" tapered(CTS), STKM	9-100	9mm-Dropout	Al	180mm	Post 160 Direct	with lamp mount*	with long fender mount
SF21	XCM32-ATB DS NLO 27.5"	-	27.5"x2.4"	80 100 120	NLO	COIL w/ Preload adjuster	503	44	AC4C	-	32	STKM	Cr-plating	130	1.5"to1-1/8" tapered(CTS), STKM	9-100	9mm-Dropout	Al	180mm	Post 160 Direct	with lamp mount*	with long fender mount

*Front face on fork crown

SPECIFICATIONS

// 2022





MODEL YEAR	MODEL NAME	MAIN SPECIFICATIONS							CROWN		STANCHION			STEERER TUBE	AXLE		BOTTOM CASE / BRAKE			
		Weight (g) w/o axle	Wheel	Travel (mm)	Damper	Spring	Axle to crown (mm)	Offset (mm)	Mat.	Method	DIA (mm)	Mat.	Finish	Pitch (mm)	Size Material	O.L.D.	Axle	Mat.	Max rotor DIA.	Brake mount
SF19	XCM34-Boost LOR DS 15AH2-110 29"	3420	29"	100/120 130	LOR	COIL w/ Preload adjuster	561	51	AC4C	-	34	STKM	Cr-plating	145	1.5"to1-1/8" tapered(CTS), STKM	ø15-110	15AH2-110/(OP) 15QLC32-110	Al	203mm	Post 160 Direct
SF19	XCM34-Boost RL DS 15AH2-110 29"	3420	29"	100/120 130	RL	COIL w/ Preload adjuster	561	51	AC4C	-	34	STKM	Cr-plating	145	1.5"to1-1/8" tapered(CTS), STKM	ø15-110	15AH2-110/(OP) 15QLC32-110	Al	203mm	Post 160 Direct
SF19	XCM34-Boost LO DS 15AH2-110 29"	3420	29"	100/120 130	LO	COIL w/ Preload adjuster	561	51	AC4C	-	34	STKM	Cr-plating	145	1.5"to1-1/8" tapered(CTS), STKM	ø15-110	15AH2-110/(OP) 15QLC32-110	Al	203mm	Post 160 Direct
SF19	XCM34-Boost NLO DS 15AH2-110 29"	3420	29"	100/120 130	NLO	COIL w/ Preload adjuster	561	51	AC4C	-	34	STKM	Cr-plating	145	1.5"to1-1/8" tapered(CTS), STKM	ø15-110	15AH2-110/(OP) 15QLC32-110	Al	203mm	Post 160 Direct
SF19	XCM34-Boost DS 15AH2-110 29"	3420	29"	100/120 130	-	COIL w/ Preload adjuster	561	51	AC4C	-	34	STKM	Cr-plating	145	1.5"to1-1/8" tapered(CTS), STKM	ø15-110	15AH2-110/(OP) 15QLC32-110	Al	203mm	Post 160 Direct
SF19	XCM34-Boost LOR DS 15AH2-110 27.5"	3380	27.5"	100/120 130	LOR	COIL w/ Preload adjuster	548	47	AC4C	-	34	STKM	Cr-plating	145	1.5"to1-1/8" tapered(CTS), STKM	ø15-110	15AH2-110/(OP) 15QLC32-110	Al	203mm	Post 160 Direct
SF19	XCM34-Boost RL DS 15AH2-110 27.5"	3380	27.5"	100/120 130	RL	COIL w/ Preload adjuster	548	47	AC4C	-	34	STKM	Cr-plating	145	1.5"to1-1/8" tapered(CTS), STKM	ø15-110	15AH2-110/(OP) 15QLC32-110	Al	203mm	Post 160 Direct
SF19	XCM34-Boost LO DS 15AH2-110 27.5"	3380	27.5"	100/120 130	LO	COIL w/ Preload adjuster	548	47	AC4C	-	34	STKM	Cr-plating	145	1.5"to1-1/8" tapered(CTS), STKM	ø15-110	15AH2-110/(OP) 15QLC32-110	Al	203mm	Post 160 Direct
SF19	XCM34-Boost NLO DS 15AH2-110 27.5"	3380	27.5"	100/120 130	NLO	COIL w/ Preload adjuster	548	47	AC4C	-	34	STKM	Cr-plating	145	1.5"to1-1/8" tapered(CTS), STKM	ø15-110	15AH2-110/(OP) 15QLC32-110	Al	203mm	Post 160 Direct
SF19	XCM34-Boost DS 15AH2-110 27.5"	3380	27.5"	100/120 130	-	COIL w/ Preload adjuster	548	47	AC4C	-	34	STKM	Cr-plating	145	1.5"to1-1/8" tapered(CTS), STKM	ø15-110	15AH2-110/(OP) 15QLC32-110	Al	203mm	Post 160 Direct



MODEL YEAR	MODEL NAME	MAIN SPECIFICATIONS							CROWN		STANCHION				STEERER TUBE	AXLE		BOTTOM CASE / BRAKE		
		Weight (g) w/o axle	Wheel	Travel (mm)	Damper	Spring	Axle to crown (mm)	Offset (mm)	Mat.	Method	DIA (mm)	Mat.	Finish	Pitch (mm)	Size Material	O.L.D.	Axle	Mat.	Max rotor DIA.	Brake mount
SF19	XCM32-Boost LOR DS 15AH2-110 29"	3330	29"	80/100 120	LOR	COIL w/ Preload adjuster	541.5	47	AC4C	-	32	STKM	Cr-plating	140	1.5"to1-1/8" tapered(CTS), STKM	ø15-110	15AH2-110/ (OP) 15QLC32-110	Al	180mm	Post 160 Direct
SF19	XCM32-Boost RL DS 15AH2-110 29"	3330	29"	80/100 120	RL	COIL w/ Preload adjuster	541.5	47	AC4C	-	32	STKM	Cr-plating	140	1.5"to1-1/8" tapered(CTS), STKM	ø15-110	15AH2-110/ (OP) 15QLC32-110	Al	180mm	Post 160 Direct
SF19	XCM32-Boost LO DS 15AH2-110 29"	3330	29"	80/100 120	LO	COIL w/ Preload adjuster	541.5	47	AC4C	-	32	STKM	Cr-plating	140	1.5"to1-1/8" tapered(CTS), STKM	ø15-110	15AH2-110/ (OP) 15QLC32-110	Al	180mm	Post 160 Direct
SF19	XCM32-Boost NLO DS 15AH2-110 29"	3330	29"	80/100 120	NLO	COIL w/ Preload adjuster	541.5	47	AC4C	-	32	STKM	Cr-plating	140	1.5"to1-1/8" tapered(CTS), STKM	ø15-110	15AH2-110/ (OP) 15QLC32-110	Al	180mm	Post 160 Direct
SF19	XCM32-Boost DS 15AH2-110 29"	3330	29"	80/100 120	-	COIL w/ Preload adjuster	541.5	47	AC4C	-	32	STKM	Cr-plating	140	1.5"to1-1/8" tapered(CTS), STKM	ø15-110	15AH2-110/ (OP) 15QLC32-110	Al	180mm	Post 160 Direct
SF19	XCM32-Boost LOR DS 15AH2-110 27.5"	3280	27.5"	80/100 120	LOR	COIL w/ Preload adjuster	528.5	47	AC4C	-	32	STKM	Cr-plating	140	1.5"to1-1/8" tapered(CTS), STKM	ø15-110	15AH2-110/ (OP) 15QLC32-110	Al	180mm	Post 160 Direct
SF19	XCM32-Boost RL DS 15AH2-110 27.5"	3280	27.5"	80/100 120	RL	COIL w/ Preload adjuster	528.5	47	AC4C	-	32	STKM	Cr-plating	140	1.5"to1-1/8" tapered(CTS), STKM	ø15-110	15AH2-110/ (OP) 15QLC32-110	Al	180mm	Post 160 Direct
SF19	XCM32-Boost LO DS 15AH2-110 27.5"	3280	27.5"	80/100 120	LO	COIL w/ Preload adjuster	528.5	47	AC4C	-	32	STKM	Cr-plating	140	1.5"to1-1/8" tapered(CTS), STKM	ø15-110	15AH2-110/ (OP) 15QLC32-110	Al	180mm	Post 160 Direct
SF19	XCM32-Boost NLO DS 15AH2-110 27.5"	3280	27.5"	80/100 120	NLO	COIL w/ Preload adjuster	528.5	47	AC4C	-	32	STKM	Cr-plating	140	1.5"to1-1/8" tapered(CTS), STKM	ø15-110	15AH2-110/ (OP) 15QLC32-110	Al	180mm	Post 160 Direct
SF19	XCM32-Boost DS 15AH2-110 27.5"	3280	27.5"	80/100 120	-	COIL w/ Preload adjuster	528.5	47	AC4C	-	32	STKM	Cr-plating	140	1.5"to1-1/8" tapered(CTS), STKM	ø15-110	15AH2-110/ (OP) 15QLC32-110	Al	180mm	Post 160 Direct



MODEL YEAR	MODEL NAME	MAIN SPECIFICATIONS						CROWN		STANCHION			STEERER TUBE		AXLE		BOTTOM CASE / BRAKE			
		Weight (g) w/o axle	Wheel	Travel (mm)	Damper	Spring	Axle to crown (mm)	Offset (mm)	Mat.	Method	DIA (mm)	Mat.	Finish	Pitch (mm)	Size Material	O.L.D.	Axle	Mat.	Max rotor DIA.	Brake mount
SF19	XCM32 LOR DS 15AH2 29"	3140	29"	80/100 120	LOR	COIL w/ Preload adjuster	537	46	AC4C	-	32	STKM	Cr-plating	130	1-1/8"(TS), STKM/ (OP) 1.5"to1-1/8" tapered(CTS), STKM	ø15-100	15AH2/ (OP) 15QLC32	Al	180mm	Post 160 Direct
SF19	XCM32 RL DS 15AH2 29"	3140	29"	80/100 120	RL	COIL w/ Preload adjuster	537	46	AC4C	-	32	STKM	Cr-plating	130	1-1/8"(TS), STKM/ (OP) 1.5"to1-1/8" tapered(CTS), STKM	ø15-100	15AH2/ (OP) 15QLC32	Al	180mm	Post 160 Direct
SF19	XCM32 LO DS 15AH2 29"	3140	29"	80/100 120	LO	COIL w/ Preload adjuster	537	46	AC4C	-	32	STKM	Cr-plating	130	1-1/8"(TS), STKM/ (OP) 1.5"to1-1/8" tapered(CTS), STKM	ø15-100	15AH2/ (OP) 15QLC32	Al	180mm	Post 160 Direct
SF19	XCM32 NLO DS 15AH2 29"	3140	29"	80/100 120	NLO	COIL w/ Preload adjuster	537	46	AC4C	-	32	STKM	Cr-plating	130	1-1/8"(TS), STKM/ (OP) 1.5"to1-1/8" tapered(CTS), STKM	ø15-100	15AH2/ (OP) 15QLC32	Al	180mm	Post 160 Direct
SF19	XCM32 DS 15AH2 29"	3140	29"	80/100 120	-	COIL w/ Preload adjuster	537	46	AC4C	-	32	STKM	Cr-plating	130	1-1/8"(TS), STKM/ (OP) 1.5"to1-1/8" tapered(CTS), STKM	ø15-100	15AH2/ (OP) 15QLC32	Al	180mm	Post 160 Direct
SF19	XCM32 LOR DS 15AH2 27.5"	3100	27.5"	80/100 120	LOR	COIL w/ Preload adjuster	517	42	AC4C	-	32	STKM	Cr-plating	130	1-1/8"(TS), STKM/ (OP) 1.5"to1-1/8" tapered(CTS), STKM	ø15-100	15AH2/ (OP) 15QLC32	Al	180mm	Post 160 Direct
SF19	XCM32 RL DS 15AH2 27.5"	3100	27.5"	80/100 120	RL	COIL w/ Preload adjuster	517	42	AC4C	-	32	STKM	Cr-plating	130	1-1/8"(TS), STKM/ (OP) 1.5"to1-1/8" tapered(CTS), STKM	ø15-100	15AH2/ (OP) 15QLC32	Al	180mm	Post 160 Direct
SF19	XCM32 LO DS 15AH2 27.5"	3100	27.5"	80/100 120	LO	COIL w/ Preload adjuster	517	42	AC4C	-	32	STKM	Cr-plating	130	1-1/8"(TS), STKM/ (OP) 1.5"to1-1/8" tapered(CTS), STKM	ø15-100	15AH2/ (OP) 15QLC32	Al	180mm	Post 160 Direct
SF19	XCM32 NLO DS 15AH2 27.5"	3100	27.5"	80/100 120	NLO	COIL w/ Preload adjuster	517	42	AC4C	-	32	STKM	Cr-plating	130	1-1/8"(TS), STKM/ (OP) 1.5"to1-1/8" tapered(CTS), STKM	ø15-100	15AH2/ (OP) 15QLC32	Al	180mm	Post 160 Direct
SF19	XCM32 DS 15AH2 27.5"	3100	27.5"	80/100 120	-	COIL w/ Preload adjuster	517	42	AC4C	-	32	STKM	Cr-plating	130	1-1/8"(TS), STKM/ (OP) 1.5"to1-1/8" tapered(CTS), STKM	ø15-100	15AH2/ (OP) 15QLC32	Al	180mm	Post 160 Direct

PLUS 24"

JR 20"



MODEL YEAR	MODEL NAME	MAIN SPECIFICATIONS						CROWN		STANCHION				STEERER TUBE		AXLE		BOTTOM CASE / BRAKE		
		Weight (g) w/o axle	Wheel	Travel (mm)	Damper	Spring	Axle to crown (mm)	Offset (mm)	Mat.	Method	DIA (mm)	Mat.	Finish	Pitch (mm)	Size Material	O.L.D.	Axle	Mat.	Max rotor DIA.	Brake mount
SF20	XCM RL DS 29"	2776	29"	80/100	RL	COIL w/ Preload adjuster	515	46	AC4C	-	30	STKM	Cr-plating	130	1-1/8"(TS), STKM/ (OP) 1.5"to1-1/8" tapered(CTS), STKM	9-100	9mm-Dropout	Al	180mm	Post 160 Direct
SF20	XCM LO DS 29"	2785	29"	80/100	LO	COIL w/ Preload adjuster	515	46	AC4C	-	30	STKM	Cr-plating	130	1-1/8"(TS), STKM/ (OP) 1.5"to1-1/8" tapered(CTS), STKM	9-100	9mm-Dropout	Al	180mm	Post 160 Direct
SF20	XCM HLO DS 29"	2760	29"	80/100	HLO	COIL w/ Preload adjuster	515	46	AC4C	-	30	STKM	Cr-plating	130	1-1/8"(TS), STKM/ (OP) 1.5"to1-1/8" tapered(CTS), STKM	9-100	9mm-Dropout	Al	180mm	Post 160 Direct
SF20	XCM DS 29"	2738	29"	80/100	-	COIL w/ Preload adjuster	515	46	AC4C	-	30	STKM	Cr-plating	130	1-1/8"(TS), STKM/ (OP) 1.5"to1-1/8" tapered(CTS), STKM	9-100	9mm-Dropout	Al	180mm	Post 160 Direct
SF20	XCM RL DS 27.5"	2760	27.5"	80/100 120	RL	COIL w/ Preload adjuster	515	46	AC4C	-	30	STKM	Cr-plating	130	1-1/8"(TS), STKM/ (OP) 1.5"to1-1/8" tapered(CTS), STKM	9-100	9mm-Dropout	Al	180mm	Post 160 Direct
SF20	XCM LO DS 27.5"	2678	27.5"	80/100 120	LO	COIL w/ Preload adjuster	515	46	AC4C	-	30	STKM	Cr-plating	130	1-1/8"(TS), STKM/ (OP) 1.5"to1-1/8" tapered(CTS), STKM	9-100	9mm-Dropout	Al	180mm	Post 160 Direct
SF20	XCM HLO DS 27.5"	2700	27.5"	80/100 120	HLO	COIL w/ Preload adjuster	515	46	AC4C	-	30	STKM	Cr-plating	130	1-1/8"(TS), STKM/ (OP) 1.5"to1-1/8" tapered(CTS), STKM	9-100	9mm-Dropout	Al	180mm	Post 160 Direct
SF20	XCM DS 27.5"	2650	27.5"	80/100 120	-	COIL w/ Preload adjuster	515	46	AC4C	-	30	STKM	Cr-plating	130	1-1/8"(TS), STKM/ (OP) 1.5"to1-1/8" tapered(CTS), STKM	9-100	9mm-Dropout	Al	180mm	Post 160 Direct
SF20	XCM RL DS 26"	2680	26"	80/100 120	RL	COIL w/ Preload adjuster	502	40	AC4C	-	30	STKM	Cr-plating	130	1-1/8"(TS), STKM/ (OP) 1.5"to1-1/8" tapered(CTS), STKM	9-100	9mm-Dropout	Al	180mm	Post 160 Direct
SF13	XCM RL P 26"	2680	26"	80/100 120	RL	COIL w/ Preload adjuster	502	40	AC4C	-	30	STKM	Cr-plating	130	1-1/8"(TS), STKM/ (OP) 1.5"to1-1/8" tapered(CTS), STKM	9-100	9mm-Dropout	Al	180mm	V-Brake +Post
SF20	XCM LO DS 26"	2679	26"	80/100 120	LO	COIL w/ Preload adjuster	502	40	AC4C	-	30	STKM	Cr-plating	130	1-1/8"(TS), STKM/ (OP) 1.5"to1-1/8" tapered(CTS), STKM	9-100	9mm-Dropout	Al	180mm	Post 160 Direct
SF13	XCM LO P 26"	2679	26"	80/100 120	LO	COIL w/ Preload adjuster	502	40	AC4C	-	30	STKM	Cr-plating	130	1-1/8"(TS), STKM/ (OP) 1.5"to1-1/8" tapered(CTS), STKM	9-100	9mm-Dropout	Al	180mm	V-Brake +Post
SF20	XCM HLO DS 26"	2665	26"	80/100 120	HLO	COIL w/ Preload adjuster	502	40	AC4C	-	30	STKM	Cr-plating	130	1-1/8"(TS), STKM/ (OP) 1.5"to1-1/8" tapered(CTS), STKM	9-100	9mm-Dropout	Al	180mm	Post 160 Direct
SF20	XCM DS 26"	2635	26"	80/100 120	-	COIL w/ Preload adjuster	502	40	AC4C	-	30	STKM	Cr-plating	130	1-1/8"(TS), STKM/ (OP) 1.5"to1-1/8" tapered(CTS), STKM	9-100	9mm-Dropout	Al	180mm	Post 160 Direct
SF13	XCM P 26"	2635	26"	80/100 120	-	COIL w/ Preload adjuster	502	40	AC4C	-	30	STKM	Cr-plating	130	1-1/8"(TS), STKM/ (OP) 1.5"to1-1/8" tapered(CTS), STKM	9-100	9mm-Dropout	Al	180mm	V-Brake +Post
SF17	XCM30-Boost DS 15QLC32-110 24"+	2800	24"+	80	-	COIL w/ Preload adjuster	462	40	AC4C	-	30	STKM	Cr-plating	138	1-1/8"(TS), STKM	ø15-110	15QLC32-110	Al	180mm	Post 160 Direct
SF18	XCM-JR-AIR SL HLO DS 20"	-	20"x2.2"	80	HLO	AIR	388.5	40	AC4C	-	28	Alloy	Hard anodized, Gold	126	1-1/8"(TS), Alloy	9-100	9mm-Dropout	Al	160mm	Post 160 Direct



MODEL YEAR	MODEL NAME	MAIN SPECIFICATIONS						CROWN		STANCHION				STEERER TUBE	AXLE		BOTTOM CASE / BRAKE			
		Weight (g) w/o axle	Wheel	Travel (mm)	Damper	Spring	Axle to crown (mm)	Offset (mm)	Mat.	Method	DIA (mm)	Mat.	Finish	Pitch (mm)	Size Material	O.L.D.	Axle	Mat.	Max rotor DIA.	Brake mount
SF19	XCT30 HLO DS 29"	-	29"	80/100	HLO	COIL w/ Preload adjuster	514	46	AC4C	-	30	STKM	Cr-plating	130	1-1/8"(TS), STKM	9-100	9mm-Dropout	Al	180mm	Post 160 Direct
SF19	XCT30 DS 29"	-	29"	80/100	-	COIL w/ Preload adjuster	514	46	AC4C	-	30	STKM	Cr-plating	130	1-1/8"(TS), STKM	9-100	9mm-Dropout	Al	180mm	Post 160 Direct
SF19	XCT30 HLO DS 27.5"	-	27.5"	80/100	HLO	COIL w/ Preload adjuster	496	42	AC4C	-	30	STKM	Cr-plating	130	1-1/8"(TS), STKM	9-100	9mm-Dropout	Al	180mm	Post 160 Direct
SF19	XCT30 DS 27.5"	-	27.5"	80/100	-	COIL w/ Preload adjuster	496	42	AC4C	-	30	STKM	Cr-plating	130	1-1/8"(TS), STKM	9-100	9mm-Dropout	Al	180mm	Post 160 Direct
SF17	XCT DS 20" Plus	2120	20"x2.8"	60	-	COIL w/ Preload adjuster	382	40	AC4C	-	28	STKM	Cr-plating	138	1-1/8"(TS), STKM	9-110	9mm-Dropout	Al	160mm	Post 160 Direct
SF19	XCT-Plus DS AIR NLO 24"	2500	24"	70	NLO	AIR	438.5	40	AC4C	-	25.4	STKM	Cr-plating	138	1-1/8"(TS), STKM	9-110	9mm-Dropout	Al	160mm	Post 160 Direct
SF19	XCT-Plus-E DS AIR NLO 24"	2250	24"	70	NLO	AIR	438.5	40	AC4C	-	25.4	Alloy	Hard anodized, Gold	138	1-1/8"(TS), Alloy	9-110	9mm-Dropout	Al	160mm	Post 160 Direct

JR-P 24"

JR 20"



MODEL YEAR	MODEL NAME	MAIN SPECIFICATIONS						CROWN		STANCHION			STEERER TUBE Size Material	AXLE		BOTTOM CASE / BRAKE				
		Weight (g) w/o axle	Wheel	Travel (mm)	Damper	Spring	Axle to crown (mm)	Offset (mm)	Mat.	Method	DIA (mm)	Mat.		Finish	Pitch (mm)	O.L.D.	Axle	Mat.	Max rotor DIA.	Brake mount
SF16	XCT-JR-L HLO DS 24"	2320	24"	80	HLO	COIL w/ Preload adjuster	443	40	AC4C	-	28	STKM	Cr-plating	126	1-1/8"(TS), STKM	9-100	9mm-Dropout	Al	160mm	Post 160 Direct
SF16	XCT-JR-L DS 24"	2320	24"	80	-	COIL w/ Preload adjuster	443	40	AC4C	-	28	STKM	Cr-plating	126	1-1/8"(TS), STKM	9-100	9mm-Dropout	Al	160mm	Post 160 Direct
SF16	XCT-JR-L DS 20"	2100	20"	63	-	COIL w/ Preload adjuster	372	40	AC4C	-	28	STKM	Cr-plating	126	1-1/8"(TS), STKM	9-100	9mm-Dropout	Al	160mm	Post 160 Direct
SF18	XCT-JR P+DS 24"	-	24"	50	-	COIL w/ Preload adjuster	415	40	AC4C	-	25.4	STKM	Cr-plating	126	1-1/8"(TS), STKM	9-100	9mm-Dropout	Al	160mm	V-Brake +Post
SF20	XCT-JR DS 24"	1985	24"	50	-	COIL w/ Preload adjuster	415	40	AC4C	-	25.4	STKM	Cr-plating	126	1-1/8"(TS), STKM	9-100	9mm-Dropout	Al	160mm	Post 160 Direct
SF12	XCT-JR P 24"	1985	24"	50	-	COIL w/ Preload adjuster	415	40	AC4C	-	25.4	STKM	Cr-plating	126	1-1/8"(TS), STKM	9-100	9mm-Dropout	Al	160mm	V-Brake
SF13	XCT-JR P 20"	1940	20"	40	-	COIL w/ Preload adjuster	351	40	AC4C	-	25.4	STKM	Cr-plating	126	1-1/8"(TS), STKM	9-100	9mm-Dropout	Al	160mm	V-Brake +Post

DS 29"

P 29"



MODEL YEAR	MODEL NAME	MAIN SPECIFICATIONS						CROWN		STANCHION				STEERER TUBE	AXLE		BOTTOM CASE / BRAKE			
		Weight (g) w/o axle	Wheel	Travel (mm)	Damper	Spring	Axle to crown (mm)	Offset (mm)	Mat.	Method	DIA (mm)	Mat.	Finish	Pitch (mm)	Size Material	O.L.D.	Axle	Mat.	Max rotor DIA.	Brake mount
SF18	XCE28 DS 29"	2660	29"	80/100	-	COIL w/Preload adjuster	515	46	AC4C	-	28	STKM	Cr-plating	126	1-1/8"(TS), STKM	9-100	9mm-Dropout	Al	180mm	Post 160 Direct
SF18	XCE28 P 29"	2660	29"	80/100	-	COIL w/Preload adjuster	515	46	AC4C	-	28	STKM	Cr-plating	126	1-1/8"(TS), STKM	9-100	9mm-Dropout	Al	-	V-Brake
SF18	XCE28 DS 27.5"	2630	27.5"	80/100	-	COIL w/Preload adjuster	497	42	AC4C	-	28	STKM	Cr-plating	126	1-1/8"(TS), STKM	9-100	9mm-Dropout	Al	180mm	Post 160 Direct
SF18	XCE28 P 27.5"	2630	27.5"	80/100	-	COIL w/Preload adjuster	497	42	AC4C	-	28	STKM	Cr-plating	126	1-1/8"(TS), STKM	9-100	9mm-Dropout	Al	-	V-Brake
SF18	XCE28 DS 26"	2600	26"	80/100	-	COIL w/Preload adjuster	483	40	AC4C	-	28	STKM	Cr-plating	126	1-1/8"(TS), STKM	9-100	9mm-Dropout	Al	180mm	Post 160 Direct
SF18	XCE28 P 26"	2600	26"	80/100	-	COIL w/Preload adjuster	483	40	AC4C	-	28	STKM	Cr-plating	126	1-1/8"(TS), STKM	9-100	9mm-Dropout	Al	-	V-Brake

M3010

CASUAL MTB

700^C

26"

24"

20"

25.4 mm

P 700C

P 24"



MODEL YEAR	MODEL NAME	MAIN SPECIFICATIONS							CROWN		STANCHION			STEERER TUBE		AXLE		BOTTOM CASE / BRAKE		
		Weight (g) w/o axle	Wheel	Travel (mm)	Damper	Spring	Axle to crown (mm)	Offset (mm)	Mat.	Method	DIA (mm)	Mat.	Finish	Pitch (mm)	Size	Material	O.L.D.	Axle	Mat.	Max rotor DIA.
SF14	M3010-A P 700C	2269	700C	40/50 63	-	COIL w/ Preload adjuster	487.2	42	AC4C	-	25.4	STKM	Cr-plating	108	1-1/8"(TS), STKM	9-100	9mm-Dropout	Al	-	V-Brake
SF14	M3010 P 700C	2250	700C	40/50 63	-	COIL	487.2	42	AC4C	-	25.4	STKM	Cr-plating	108	1-1/8"(TS), STKM	9-100	9mm-Dropout	Al	-	V-Brake
SF15	M3010-A P 26"	2260	26"	50/63	-	COIL w/ Preload adjuster	453.4	42	AC4C	-	25.4	STKM	Cr-plating	108	1-1/8"(TS), STKM	9-100	9mm-Dropout	Al	-	V-Brake
SF15	M3010 P 26"	2240	26"	50/63	-	COIL	453.4	42	AC4C	-	25.4	STKM	Cr-plating	108	1-1/8"(TS), STKM	9-100	9mm-Dropout	Al	-	V-Brake
SF15	M3010-A P 24"	2180	24"	50	-	COIL w/ Preload adjuster	417.2	42	AC4C	-	25.4	STKM	Cr-plating	108	1-1/8"(TS), STKM	9-100	9mm-Dropout	Al	-	V-Brake
SF15	M3010 P 24"	2160	24"	50	-	COIL	417.2	42	AC4C	-	25.4	STKM	Cr-plating	108	1-1/8"(TS), STKM	9-100	9mm-Dropout	Al	-	V-Brake
SF14	M3010-A P 20"	1915	20"	40	-	COIL w/ Preload adjuster	351	42	AC4C	-	25.4	STKM	Cr-plating	108	1-1/8"(TS), STKM	9-100	9mm-Dropout	Al	-	V-Brake
SF14	M3010 P 20"	1897	20"	40	-	COIL	351	42	AC4C	-	25.4	STKM	Cr-plating	108	1-1/8"(TS), STKM	9-100	9mm-Dropout	Al	-	V-Brake

CASUAL MTB

XCE // M3010

SPECIFICATIONS

// 2022

SFSAINTOUR

MOBIE35

URBAN / UTILITY

29"

27.5"

35mm

AIR LOR 700C



MODEL YEAR	MODEL NAME	MAIN SPECIFICATIONS							CROWN		STANCHION		Pitch (mm)	STEERER TUBE Size Material	AXLE		BOTTOM CASE / BRAKE				
		Weight (g) w/o axle	Wheel	Travel (mm)	Damper	Spring	Axle to crown (mm)	Offset (mm)	Mat.	Method	DIA (mm)	Mat.			Finish	O.L.D.	Axle	Mat.	Max rotor DIA.	Brake mount	Note
SF22	MOBIE35-Boost 3CR-PCS-DS-ABS 15LH-110 29"	-	29"	120/130/ 140/150/ 160	3CR-PCS	AIR (EQ)	580	44	Alloy	Forged	35	Alloy	Hard anodized, Black	145	1.5"to1-1/8" tapered(CTS), Alloy	ø15-110	15LH-110	Mg	203mm	Post 180 Direct	with lamp mount*
SF22	MOBIE35-Boost 2CR-PCS-DS-ABS 15LH-110 29"	2250	29"	120/130/ 140/150/ 160	2CR-PCS	AIR (EQ)	580	44	Alloy	Forged	35	Alloy	Hard anodized, Black	145	1.5"to1-1/8" tapered(CTS), Alloy	ø15-110	15LH-110	Mg	203mm	Post 180 Direct	with lamp mount*
SF22	MOBIE35-Boost 3CR-PCS-DS 15LH-110-29"	-	29"	120/130/ 140/150/ 160	3CR-PCS	AIR (EQ)	580	44	Alloy	Forged	35	Alloy	Hard anodized, Black	145	1.5"to1-1/8" tapered(CTS), Alloy	ø15-110	15LH-110	Mg	203mm	Post 180 Direct	with lamp mount*
SF22	MOBIE35-Boost 2CR-PCS-DS 15LH-110 29"	-	29"	120/130/ 140/150/ 160	2CR-PCS	AIR (EQ)	580	44	Alloy	Forged	35	Alloy	Hard anodized, Black	145	1.5"to1-1/8" tapered(CTS), Alloy	ø15-110	15LH-110	Mg	203mm	Post 180 Direct	with lamp mount*
SF22	MOBIE35-Boost 3CR-PCS-DS-ABS 15LH-110 27.5"	-	27.5"	120/130/ 140/150/ 160	3CR-PCS	AIR (EQ)	565.5	44	Alloy	Forged	35	Alloy	Hard anodized, Black	145	1.5"to1-1/8" tapered(CTS), Alloy	ø15-110	15LH-110	Mg	203mm	Post 180 Direct	with lamp mount*
SF22	MOBIE35-Boost 2CR-PCS-DS-ABS 15LH-110 27.5"	-	27.5"	120/130/ 140/150/ 160	2CR-PCS	AIR (EQ)	565.5	44	Alloy	Forged	35	Alloy	Hard anodized, Black	145	1.5"to1-1/8" tapered(CTS), Alloy	ø15-110	15LH-110	Mg	203mm	Post 180 Direct	with lamp mount*
SF22	MOBIE35-Boost 3CR-PCS-DS 15LH-110 27.5"	-	27.5"	120/130/ 140/150/ 160	3CR-PCS	AIR (EQ)	565.5	44	Alloy	Forged	35	Alloy	Hard anodized, Black	145	1.5"to1-1/8" tapered(CTS), Alloy	ø15-110	15LH-110	Mg	203mm	Post 180 Direct	with lamp mount*
SF22	MOBIE35-Boost 2CR-PCS-DS 15LH-110 27.5"	-	27.5"	120/130/ 140/150/ 160	2CR-PCS	AIR (EQ)	565.5	44	Alloy	Forged	35	Alloy	Hard anodized, Black	145	1.5"to1-1/8" tapered(CTS), Alloy	ø15-110	15LH-110	Mg	203mm	Post 180 Direct	with lamp mount*

*Front face on fork crown

MOBIE34

URBAN / UTILITY

27.5"

700^G

20"

34 mm



2CR 700C



E-BIKE READY



CGO LO 20"



E-BIKE READY



GLOSS BLACK

MATT BLACK

GLOSS WHITE

MODEL YEAR	MODEL NAME	MAIN SPECIFICATIONS							CROWN		STANCHION			STEERER TUBE	AXLE		BOTTOM CASE / BRAKE				
		Weight (g) w/o axle	Wheel	Travel (mm)	Damper	Spring	Axle to crown (mm)	Offset (mm)	Mat.	Method	DIA (mm)	Mat.	Finish	Pitch (mm)	Size Material	O.L.D.	Axle	Mat.	Max rotor DIA.	Brake mount	Note
SF21	MOBIE34 2CR DS ABS 15QLC32 700C	2150	700C	80 100	2CR	AIR	518.5	44	Alloy	Forged	34	Alloy	Hard anodized, Black	132	1.5"to1-1/8" tapered(CTS), Alloy	ø15-100	15QLC32	Mg	203mm	Post 180 Direct	with lamp mount*
SF21	MOBIE34 2CR DS 15QLC32 700C	-	700C	80 100	2CR	AIR	518.5	44	Alloy	Forged	34	Alloy	Hard anodized, Black	132	1.5"to1-1/8" tapered(CTS), Alloy	ø15-100	15QLC32	Mg	203mm	Post 180 Direct	with lamp mount*
SF21	MOBIE34 2CR DS ABS 15QLC32 27.5"	-	27.5"	80 100	2CR	AIR	501	44	Alloy	Forged	34	Alloy	Hard anodized, Black	132	1.5"to1-1/8" tapered(CTS), Alloy	ø15-100	15QLC32	Mg	203mm	Post 180 Direct	with lamp mount*
SF21	MOBIE34 2CR DS 15QLC32 27.5"	-	27.5"	80 100	2CR	AIR	501	44	Alloy	Forged	34	Alloy	Hard anodized, Black	132	1.5"to1-1/8" tapered(CTS), Alloy	ø15-100	15QLC32	Mg	203mm	Post 180 Direct	with lamp mount*
SF21	MOBIE34-D 2CR DS 15QLC32 700C	2360	700C	80 100	2CR	AIR	518.5	44	Alloy	Forged	34	STKM	Black	132	1.5"to1-1/8" tapered(CTS), Alloy	ø15-100	15QLC32	Mg	203mm	Post 180 Direct	with lamp mount*
SF21	MOBIE34-D 2CR DS 15QLC32 27.5"	-	27.5"	80 100	2CR	AIR	501	44	Alloy	Forged	34	STKM	Black	132	1.5"to1-1/8" tapered(CTS), Alloy	ø15-100	15QLC32	Mg	203mm	Post 180 Direct	with lamp mount*
SF22	MOBIE34-CGO Boost DS LO 15AH2-110 20"	-	20"	80 100	LO	AIR	390	44	Alloy	Forged	34	STKM	Black	145	1.5"to1-1/8" tapered(CTS), reinforced STKM	ø15-110	15AH2-110	Mg	203mm	Post 180 Direct	with lamp mount*
SF22	MOBIE34-CGO Boost DS 15AH2-110 20"	-	20"	80 100	-	AIR	390	44	Alloy	Forged	34	STKM	Black	145	1.5"to1-1/8" tapered(CTS), reinforced STKM	ø15-110	15AH2-110	Mg	203mm	Post 180 Direct	with lamp mount*

*Front face on fork crown

URBAN / UTILITY

MOBIE35 / 34

SPECIFICATIONS

// 2022



MOBIE45

URBAN / UTILITY

27.5" U

700 C

34 mm

AIR LOR 700C



MODEL YEAR	MODEL NAME	MAIN SPECIFICATIONS							CROWN		STANCHION				STEERER TUBE	AXLE		BOTTOM CASE / BRAKE			
		Weight (g) w/o axle	Wheel	Travel (mm)	Damper	Spring	Axle to crown (mm)	Offset (mm)	Mat.	Method	DIA (mm)	Mat.	Finish	Pitch (mm)	Size Material	O.L.D.	Axle	Mat.	Max rotor DIA.	Brake mount	Note
SF18	MOBIE45-AIR RLR DS 15QLC32 700C	1943	700C	60/80 100	RLR	AIR	518.5	44	Alloy	Forged	34	Alloy	Hard anodized, Black	132	1.5"to 1-1/8" tapered(CTS), Alloy	ø15-100	15QLC32	Mg	203mm	Post 160 Direct	with lamp mount*
SF18	MOBIE45-AIR LOR DS 15QLC32 700C	1940	700C	60/80 100	LOR	AIR	518.5	44	Alloy	Forged	34	Alloy	Hard anodized, Black	132	1.5"to 1-1/8" tapered(CTS), Alloy	ø15-100	15QLC32	Mg	203mm	Post 160 Direct	with lamp mount*
SF18	MOBIE45-COIL RLR DS 15QLC32 700C	2264	700C	60/80 100	RLR	COIL w/ Preload adjuster	518.5	44	Alloy	Forged	34	Alloy	Hard anodized, Black	132	1.5"to 1-1/8" tapered(CTS), Alloy	ø15-100	15QLC32	Mg	203mm	Post 160 Direct	with lamp mount*
SF18	MOBIE45-COIL LOR DS 15QLC32 700C	2260	700C	60/80 100	LOR	COIL w/ Preload adjuster	518.5	44	Alloy	Forged	34	Alloy	Hard anodized, Black	132	1.5"to 1-1/8" tapered(CTS), Alloy	ø15-100	15QLC32	Mg	203mm	Post 160 Direct	with lamp mount*
SF18	MOBIE45-AIR RLR DS 15QLC32 27.5"	1960	27.5"	60/80 100	RLR	AIR	501	44	Alloy	Forged	34	Alloy	Hard anodized, Black	132	1.5"to 1-1/8" tapered(CTS), Alloy	ø15-100	15QLC32	Mg	203mm	Post 160 Direct	with lamp mount*
SF18	MOBIE45-AIR LOR DS 15QLC32 27.5"	1940	27.5"	60/80 100	LOR	AIR	501	44	Alloy	Forged	34	Alloy	Hard anodized, Black	132	1.5"to 1-1/8" tapered(CTS), Alloy	ø15-100	15QLC32	Mg	203mm	Post 160 Direct	with lamp mount*
SF18	MOBIE45-COIL RLR DS 15QLC32 27.5"	2264	27.5"	60/80 100	RLR	COIL w/ Preload adjuster	501	44	Alloy	Forged	34	Alloy	Hard anodized, Black	132	1.5"to 1-1/8" tapered(CTS), Alloy	ø15-100	15QLC32	Mg	203mm	Post 160 Direct	with lamp mount*
SF18	MOBIE45-COIL LOR DS 15QLC32 27.5"	2260	27.5"	60/80 100	LOR	COIL w/ Preload adjuster	501	44	Alloy	Forged	34	Alloy	Hard anodized, Black	132	1.5"to 1-1/8" tapered(CTS), Alloy	ø15-100	15QLC32	Mg	203mm	Post 160 Direct	with lamp mount*

*Front face on fork crown

MOBIE25

URBAN / UTILITY

27.5"

700^C

32mm

AIR LOR 700C



GLOSS BLACK

MATT BLACK

GLOSS WHITE

URBAN / UTILITY

MOBIE45 / 25

MODEL YEAR	MODEL NAME	MAIN SPECIFICATIONS							CROWN		STANCHION			STEERER TUBE	AXLE		BOTTOM CASE / BRAKE				
		Weight (g) w/o axle	Wheel	Travel (mm)	Damper	Spring	Axle to crown (mm)	Offset (mm)	Mat.	Method	DIA (mm)	Mat.	Finish	Pitch (mm)	Size Material	O.L.D.	Axle	Mat.	Max rotor DIA.	Brake mount	Note
SF18	MOBIE25-AIR RLR DS 15QLC32 700C	2120	700C	63/75 100	RLR	AIR	518.5	44	Alloy	Forged	32	Alloy	Hard anodized, Black	132	1.5"to 1-1/8" tapered(CTS), Alloy	ø15-100	15QLC32	Mg	180mm	Post 160 Direct	with lamp mount*
SF18	MOBIE25-AIR LOR DS 15QLC32 700C	2000	700C	63/75 100	LOR	AIR	518.5	44	Alloy	Forged	32	Alloy	Hard anodized, Black	132	1.5"to 1-1/8" tapered(CTS), Alloy	ø15-100	15QLC32	Mg	180mm	Post 160 Direct	with lamp mount*
SF18	MOBIE25-COIL RLR DS 15QLC32 700C	2210	700C	63/75 100	RLR	COIL w/ Preload adjuster	518.5	44	Alloy	Forged	32	Alloy	Hard anodized, Black	132	1.5"to 1-1/8" tapered(CTS), Alloy	ø15-100	15QLC32	Mg	180mm	Post 160 Direct	with lamp mount*
SF18	MOBIE25-COIL LOR DS 15QLC32 700C	2210	700C	63/75 100	LOR	COIL w/ Preload adjuster	518.5	44	Alloy	Forged	32	Alloy	Hard anodized, Black	132	1.5"to 1-1/8" tapered(CTS), Alloy	ø15-100	15QLC32	Mg	180mm	Post 160 Direct	with lamp mount*
SF18	MOBIE25-AIR RLR DS 15QLC32 27.5"	2006	27.5"	63/75 100	RLR	AIR	501	44	Alloy	Forged	32	Alloy	Hard anodized, Black	132	1.5"to 1-1/8" tapered(CTS), Alloy	ø15-100	15QLC32	Mg	180mm	Post 160 Direct	with lamp mount*
SF18	MOBIE25-AIR LOR DS 15QLC32 27.5"	2000	27.5"	63/75 100	LOR	AIR	501	44	Alloy	Forged	32	Alloy	Hard anodized, Black	132	1.5"to 1-1/8" tapered(CTS), Alloy	ø15-100	15QLC32	Mg	180mm	Post 160 Direct	with lamp mount*
SF18	MOBIE25-COIL RLR DS 15QLC32 27.5"	2210	27.5"	63/75 100	RLR	COIL w/ Preload adjuster	501	44	Alloy	Forged	32	Alloy	Hard anodized, Black	132	1.5"to 1-1/8" tapered(CTS), Alloy	ø15-100	15QLC32	Mg	180mm	Post 160 Direct	with lamp mount*
SF18	MOBIE25-COIL LOR DS 15QLC32 27.5"	2210	27.5"	63/75 100	LOR	COIL w/ Preload adjuster	501	44	Alloy	Forged	32	Alloy	Hard anodized, Black	132	1.5"to 1-1/8" tapered(CTS), Alloy	ø15-100	15QLC32	Mg	180mm	Post 160 Direct	with lamp mount*

*Front face on fork crown

SPECIFICATIONS

// 21/22



MOBIEA32

URBAN / UTILITY

29"

27.5"

20"

32mm



LO 29"



E-BIKE READY



20"



E-BIKE READY



GLOSS BLACK

MATT BLACK

GLOSS WHITE

		MAIN SPECIFICATIONS						CROWN			STANCHION			STEERER TUBE		AXLE		BOTTOM CASE / BRAKE			
MODEL YEAR	MODEL NAME	Weight (g) w/o axle	Wheel	Travel (mm)	Damper	Spring	Axle to crown (mm)	Offset (mm)	Mat.	Method	DIA (mm)	Mat.	Finish	Pitch (mm)	Size Material	O.L.D.	Axle	Mat.	Max rotor DIA.	Brake mount	Note
SF21	MOBIEA32-COIL RL DS 15AH2 29"	2170	29"	63/75	RL	COIL w/ Preload adjuster	498	44	AC4C	-	32	STKM	Cr-plating	130	1.5"to1-1/8" tapered(CTS), STKM	ø15-100	15AH2	Al	180mm	Post 160 Direct	with lamp mount*
SF21	MOBIEA32-COIL LO DS 15AH2 29"	2170	29"	63/75	LO	COIL w/ Preload adjuster	498	44	AC4C	-	32	STKM	Cr-plating	130	1.5"to1-1/8" tapered(CTS), STKM	ø15-100	15AH2	Al	180mm	Post 160 Direct	with lamp mount*
SF21	MOBIEA32-COIL NLO DS 15AH2 29"	2170	29"	63/75	NLO	COIL w/ Preload adjuster	498	44	AC4C	-	32	STKM	Cr-plating	130	1.5"to1-1/8" tapered(CTS), STKM	ø15-100	15AH2	Al	180mm	Post 160 Direct	with lamp mount*
SF21	MOBIEA32-COIL DS 15AH2 29"	2160	29"	63/75	-	COIL w/ Preload adjuster	498	44	AC4C	-	32	STKM	Cr-plating	130	1.5"to1-1/8" tapered(CTS), STKM	ø15-100	15AH2	Al	180mm	Post 160 Direct	with lamp mount*
SF21	MOBIEA32-COIL RL DS 15AH2 27.5"	2170	27.5"	63/75	RL	COIL w/ Preload adjuster	476	44	AC4C	-	32	STKM	Cr-plating	130	1.5"to1-1/8" tapered(CTS), STKM	ø15-100	15AH2	Al	180mm	Post 160 Direct	with lamp mount*
SF21	MOBIEA32-COIL LO DS 15AH2 27.5"	2170	27.5"	63/75	LO	COIL w/ Preload adjuster	476	44	AC4C	-	32	STKM	Cr-plating	130	1.5"to1-1/8" tapered(CTS), STKM	ø15-100	15AH2	Al	180mm	Post 160 Direct	with lamp mount*
SF21	MOBIEA32-COIL NLO DS 15AH2 27.5"	2170	27.5"	63/75	NLO	COIL w/ Preload adjuster	476	44	AC4C	-	32	STKM	Cr-plating	130	1.5"to1-1/8" tapered(CTS), STKM	ø15-100	15AH2	Al	180mm	Post 160 Direct	with lamp mount*
SF21	MOBIEA32-COIL DS 15AH2 27.5"	2160	27.5"	63/75	-	COIL w/ Preload adjuster	476	44	AC4C	-	32	STKM	Cr-plating	130	1.5"to1-1/8" tapered(CTS), STKM	ø15-100	15AH2	Al	180mm	Post 160 Direct	with lamp mount*
SF22	MOBIEA32-NLO DS 15AH2 20"	2700	20"x2.15"	50	NLO	COIL w/ Preload adjuster	385	38	AC4C	-	32	STKM reinforced	Cr-plating	130	1.5"to1-1/8" tapered(CTS), STKM	ø15-100	15AH2	Al	180mm	Post 160 Direct	with lamp mount*
SF22	MOBIEA32-DS 15AH2 20"	2700	20"x2.15"	50	-	COIL w/ Preload adjuster	385	38	AC4C	-	32	STKM reinforced	Cr-plating	130	1.5"to1-1/8" tapered(CTS), STKM	ø15-100	15AH2	Al	180mm	Post 160 Direct	with lamp mount*

*Front face on fork crown

LOR 700C



GRAVEL / URBAN / UTILITY

MOBIEA32 // GVX

SPECIFICATIONS

// 2102



MODEL YEAR	MODEL NAME	MAIN SPECIFICATIONS							CROWN		STANCHION				STEERER TUBE	AXLE		BOTTOM CASE / BRAKE		
		Weight (g) w/o axle	Wheel	Travel (mm)	Damper	Spring	Axle to crown (mm)	Offset (mm)	Mat.	Method	DIA (mm)	Mat.	Finish	Pitch (mm)	Size Material	O.L.D.	Axle	Mat.	Max rotor DIA.	Brake mount
SF21	GVX32-S LOR FDS 15AH2 700C	1670	700Cx45C	40	LOR	AIR	436.8	45.4	Alloy	Forged	32	Alloy	Hard anodized, Black	120	1.5"to1-1/8" tapered(CTS), Alloy	ø15-100	15AH2/(OP) 12AH	Mg	Flat 180mm	Flat 160 Direct
				50			446.8	46.2												
				60			456.7	47												
SF21	GVX32-S RLR FDS 15AH2 700C	-	700Cx45C	40	RLR	AIR	436.8	45.4	Alloy	Forged	32	Alloy	Hard anodized, Black	120	1.5"to1-1/8" tapered(CTS), Alloy	ø15-100	15AH2/(OP) 12AH	Mg	Flat 180mm	Flat 160 Direct
				50			446.8	46.2												
				60			456.7	47												



MODEL YEAR	MODEL NAME	MAIN SPECIFICATIONS							CROWN		STANCHION			STEERER TUBE	AXLE		BOTTOM CASE / BRAKE			
		Weight (g) w/o axle	Wheel	Travel (mm)	Damper	Spring	Axle to crown (mm)	Offset (mm)	Mat.	Method	DIA (mm)	Mat.	Finish	Pitch (mm)	Size Material	O.L.D.	Axle	Mat.	Max rotor DIA.	Brake mount
SF18	NRX-S RLR DS 15QLC32S 700C	1850	700C	63/75	RLR	AIR	492	46	Alloy	Forged	32	Alloy	Hard anodized, Black	120	1-1/8"(TS), Alloy/(OP) 1.5"to1-1/8" tapered(CTS), Alloy	ø15-100	15QLC32S	Mg	180mm	Post 160 Direct
SF18	NRX-S LOR DS 15QLC32S 700C	1845	700C	63/75	LOR	AIR	492	46	Alloy	Forged	32	Alloy	Hard anodized, Black	120	1-1/8"(TS), Alloy/(OP) 1.5"to1-1/8" tapered(CTS), Alloy	ø15-100	15QLC32S	Mg	180mm	Post 160 Direct
SF18	NRX-E RLR DS 15QLC32S 700C	1860	700C	63/75	RLR	AIR	492	46	Alloy	Forged	32	Alloy	Hard anodized, Black	120	1-1/8"(TS), Alloy/(OP) 1.5"to1-1/8" tapered(CTS), Alloy	ø15-100	15QLC32S	Mg	180mm	Post 160 Direct
SF18	NRX-E LOR DS 15QLC32S 700C	1865	700C	63/75	LOR	AIR	492	46	Alloy	Forged	32	Alloy	Hard anodized, Black	120	1-1/8"(TS), Alloy/(OP) 1.5"to1-1/8" tapered(CTS), Alloy	ø15-100	15QLC32S	Mg	180mm	Post 160 Direct
SF13	NRX-S RLR DS 700C	1724	700C	63/75	RLR	AIR	492	46	Alloy	Forged	30	Alloy	Hard anodized, Gold	116	1-1/8"(TS), Alloy/(OP) 1.5"to1-1/8" tapered(CTS), Alloy	9-100	9mm-Dropout	Mg	180mm	Post 160 Direct
SF13	NRX-S LOR DS 700C	1774	700C	63/75	LOR	AIR	492	46	Alloy	Forged	30	Alloy	Hard anodized, Gold	116	1-1/8"(TS), Alloy/(OP) 1.5"to1-1/8" tapered(CTS), Alloy	9-100	9mm-Dropout	Mg	180mm	Post 160 Direct
SF13	NRX-E RLR DS 700C	-	700C	63/75	RLR	AIR	492	46	Alloy	Forged	30	Alloy	Hard anodized, Gold	116	1-1/8"(TS), STKM/(OP) 1.5"to1-1/8" tapered(CTS), Alloy	9-100	9mm-Dropout	Mg	180mm	Post 160 Direct
SF13	NRX-E LOR DS 700C	1710	700C	63/75	LOR	AIR	492	46	Alloy	Forged	30	Alloy	Hard anodized, Gold	116	1-1/8"(TS), STKM/(OP) 1.5"to1-1/8" tapered(CTS), Alloy	9-100	9mm-Dropout	Mg	180mm	Post 160 Direct
SF13	NRX-E RL DS 700C	1910	700C	63/75	RL	AIR	492	46	Alloy	Forged	30	Alloy	Hard anodized, Gold	116	1-1/8"(TS), STKM/(OP) 1.5"to1-1/8" tapered(CTS), Alloy	9-100	9mm-Dropout	Mg	180mm	Post 160 Direct
SF13	NRX-E LO DS 700C	1879	700C	63/75	LO	AIR	492	46	Alloy	Forged	30	Alloy	Hard anodized, Gold	116	1-1/8"(TS), STKM/(OP) 1.5"to1-1/8" tapered(CTS), Alloy	9-100	9mm-Dropout	Mg	180mm	Post 160 Direct



MODEL YEAR	MODEL NAME	MAIN SPECIFICATIONS						CROWN		STANCHION			STEERER TUBE		AXLE		BOTTOM CASE / BRAKE			
		Weight (g) w/o axle	Wheel	Travel (mm)	Damper	Spring	Axle to crown (mm)	Offset (mm)	Mat.	Method	DIA (mm)	Mat.	Finish	Pitch (mm)	Size Material	O.L.D.	Axle	Mat.	Max rotor DIA.	Brake mount
SF13	NRX-D-AIR RL DS 700C	2112	700C	63/75	RL	AIR	492	46	AC4C	-	30	STKM	Cr-plating/ Hard anodized, Black	116	1-1/8"(TS), STKM/ (OP) 1.5"to1-1/8" tapered(CTS), Alloy	9-100	9mm- Dropout	Mg	180mm	Post 160 Direct
SF13	NRX-D-AIR RL P 700C	2112	700C	63/75	RL	AIR	492	46	AC4C	-	30	STKM	Cr-plating/ Hard anodized, Black	116	1-1/8"(TS), STKM/ (OP) 1.5"to1-1/8" tapered(CTS), Alloy	9-100	9mm- Dropout	Mg	180mm	V-Brake
SF13	NRX-D-AIR LO DS 700C	2123	700C	63/75	LO	AIR	492	46	AC4C	-	30	STKM	Cr-plating/ Hard anodized, Black	116	1-1/8"(TS), STKM/ (OP) 1.5"to1-1/8" tapered(CTS), Alloy	9-100	9mm- Dropout	Mg	180mm	Post 160 Direct
SF13	NRX-D-AIR LO P 700C	2123	700C	63/75	LO	AIR	492	46	AC4C	-	30	STKM	Cr-plating/ Hard anodized, Black	116	1-1/8"(TS), STKM/ (OP) 1.5"to1-1/8" tapered(CTS), Alloy	9-100	9mm- Dropout	Mg	-	V-Brake
SF13	NRX-D-COIL RL DS 700C	2138	700C	63/75	RL	COIL w/ Preload adjuster	492	46	AC4C	-	30	STKM	Cr-plating/ Hard anodized, Black	116	1-1/8"(TS), STKM/ (OP) 1.5"to1-1/8" tapered(CTS), Alloy	9-100	9mm- Dropout	Mg	180mm	Post 160 Direct
SF13	NRX-D-COIL RL P 700C	2138	700C	63/75	RL	COIL w/ Preload adjuster	492	46	AC4C	-	30	STKM	Cr-plating/ Hard anodized, Black	116	1-1/8"(TS), STKM/ (OP) 1.5"to1-1/8" tapered(CTS), Alloy	9-100	9mm- Dropout	Mg	-	V-Brake
SF13	NRX-D-COIL LO DS 700C	2119	700C	63/75	LO	COIL w/ Preload adjuster	492	46	AC4C	-	30	STKM	Cr-plating/ Hard anodized, Black	116	1-1/8"(TS), STKM/ (OP) 1.5"to1-1/8" tapered(CTS), Alloy	9-100	9mm- Dropout	Mg	180mm	Post 160 Direct
SF13	NRX-D-COIL LO P 700C	2119	700C	63/75	LO	COIL w/ Preload adjuster	492	46	AC4C	-	30	STKM	Cr-plating/ Hard anodized, Black	116	1-1/8"(TS), STKM/ (OP) 1.5"to1-1/8" tapered(CTS), Alloy	9-100	9mm- Dropout	Mg	-	V-Brake

NCX / TR-HSI

E RL 700C



MODEL YEAR	MODEL NAME	MAIN SPECIFICATIONS							CROWN		STANCHION		Pitch (mm)	STEERER TUBE Size Material	AXLE		BOTTOM CASE / BRAKE				
		Weight (g) w/o axle	Wheel	Travel (mm)	Damper	Spring	Axle to crown (mm)	Offset (mm)	Mat.	Method	DIA (mm)	Mat.			Finish	O.L.D.	Axle	Mat.	Max rotor DIA.	Brake mount	Note
SF17	NCX-E RL DS 15QLC32S 700C	1770	700C	50/63	RL	AIR	468	41.7	AC4C	-	30	Alloy	Hard anodized, Gold	116	1-1/8"(TS), STKM/(OP) 1-1/8"(TS), Alloy/1.5"to1-1/8" tapered(CTS), Alloy	ø15-100	15QLC32S	Mg	180mm	Post 160 Direct	with lamp mount*
SF17	NCX-E LO DS 15QLC32S 700C	1750	700C	50/63	LO	AIR	468	41.7	AC4C	-	30	Alloy	Hard anodized, Gold	116	1-1/8"(TS), STKM/(OP) 1-1/8"(TS), Alloy/1.5"to1-1/8" tapered(CTS), Alloy	ø15-100	15QLC32S	Mg	180mm	Post 160 Direct	with lamp mount*
SF17	NCX-E-AIR RL DS 700C	1650	700C	50/63	RL	AIR	468	41.7	AC4C	-	30	Alloy	Hard anodized, Gold	116	1-1/8"(TS), STKM/(OP) 1-1/8"(TS), Alloy/1.5"to1-1/8" tapered(CTS), Alloy	9-100	9mm-Dropout	Mg	180mm	Post 160 Direct	with lamp mount*
SF17	NCX-E-AIR LO DS 700C	1630	700C	50/63	LO	AIR	468	41.7	AC4C	-	30	Alloy	Hard anodized, Gold	116	1-1/8"(TS), STKM/(OP) 1-1/8"(TS), Alloy/1.5"to1-1/8" tapered(CTS), Alloy	9-100	9mm-Dropout	Mg	180mm	Post 160 Direct	with lamp mount*
SF17	NCX-D-AIR RL DS 15QLC32S 700C	-	700C	50/63	RL	AIR	468	41.7	AC4C	-	30	STKM	Ni-plating/ Hard anodized, Black	116	1-1/8"(TS), STKM/(OP) 1-1/8"(TS), Alloy/1.5"to1-1/8" tapered(CTS), Alloy	ø15-100	15QLC32S	Mg	180mm	Post 160 Direct	with lamp mount*
SF17	NCX-D-AIR LO DS 15QLC32S 700C	-	700C	50/63	LO	AIR	468	41.7	AC4C	-	30	STKM	Ni-plating/ Hard anodized, Black	116	1-1/8"(TS), STKM/(OP) 1-1/8"(TS), Alloy/1.5"to1-1/8" tapered(CTS), Alloy	ø15-100	15QLC32S	Mg	180mm	Post 160 Direct	with lamp mount*
SF17	NCX-D-COIL RL DS 15QLC32S 700C	-	700C	50/63	RL	COIL w/ Preload adjuster	468	41.7	AC4C	-	30	STKM	Ni-plating/ Hard anodized, Black	116	1-1/8"(TS), STKM/(OP) 1-1/8"(TS), Alloy/1.5"to1-1/8" tapered(CTS), Alloy	ø15-100	15QLC32S	Mg	180mm	Post 160 Direct	with lamp mount*
SF17	NCX-D-COIL LO DS 15QLC32S 700C	-	700C	50/63	LO	COIL w/ Preload adjuster	468	41.7	AC4C	-	30	STKM	Ni-plating/ Hard anodized, Black	116	1-1/8"(TS), STKM/(OP) 1-1/8"(TS), Alloy/1.5"to1-1/8" tapered(CTS), Alloy	ø15-100	15QLC32S	Mg	180mm	Post 160 Direct	with lamp mount*

*Small size type on the center of brace

D LO 700C

TR-HSI HLO 700C



MODEL YEAR	MODEL NAME	MAIN SPECIFICATIONS							CROWN			STANCHION			Pitch (mm)	STEERER TUBE Size Material	AXLE		BOTTOM CASE / BRAKE		
		Weight (g) w/o axle	Wheel	Travel (mm)	Damper	Spring	Axle to crown (mm)	Offset (mm)	Mat.	Method	DIA (mm)	Mat.	Finish	O.L.D.			Axle	Mat.	Max rotor DIA.	Brake mount	Note
SF17	NCX-D-AIR RL DS 700C	-	700C	50/63	RL	AIR	468	41.7	AC4C	-	30	STKM	Ni-plating/ Hard anodized, Black	116	1-1/8"(TS), STKM/ (OP) 1-1/8"(TS), Alloy/1.5"to1-1/8" tapered(CTS), Alloy	9-100	9mm-Dropout	Mg	180mm	Post 160 Direct	with lamp mount*
SF17	NCX-D-AIR RL P 700C	-	700C	50/63	RL	AIR	468	41.7	AC4C	-	30	STKM	Ni-plating/ Hard anodized, Black	116	1-1/8"(TS), STKM/ (OP) 1-1/8"(TS), Alloy/1.5"to1-1/8" tapered(CTS), Alloy	9-100	9mm-Dropout	Mg	180mm	V-Brake	with lamp mount*
SF17	NCX-D-AIR LO DS 700C	1950	700C	50/63	LO	AIR	468	41.7	AC4C	-	30	STKM	Ni-plating/ Hard anodized, Black	116	1-1/8"(TS), STKM/ (OP) 1-1/8"(TS), Alloy/1.5"to1-1/8" tapered(CTS), Alloy	9-100	9mm-Dropout	Mg	180mm	Post 160 Direct	with lamp mount*
SF17	NCX-D-AIR LO P 700C	-	700C	50/63	LO	AIR	468	41.7	AC4C	-	30	STKM	Ni-plating/ Hard anodized, Black	116	1-1/8"(TS), STKM/ (OP) 1-1/8"(TS), Alloy/1.5"to1-1/8" tapered(CTS), Alloy	9-100	9mm-Dropout	Mg	180mm	V-Brake	with lamp mount*
SF17	NCX-D-COIL RL P 700C	-	700C	50/63	RL	COIL w/ Preload adjuster	468	41.7	AC4C	-	30	STKM	Ni-plating/ Hard anodized, Black	116	1-1/8"(TS), STKM/ (OP) 1-1/8"(TS), Alloy/1.5"to1-1/8" tapered(CTS), Alloy	9-100	9mm-Dropout	Mg	180mm	V-Brake	with lamp mount*
SF17	NCX-D-COIL LO P 700C	-	700C	50/63	LO	COIL w/ Preload adjuster	468	41.7	AC4C	-	30	STKM	Ni-plating/ Hard anodized, Black	116	1-1/8"(TS), STKM/ (OP) 1-1/8"(TS), Alloy/1.5"to1-1/8" tapered(CTS), Alloy	9-100	9mm-Dropout	Mg	180mm	V-Brake	with lamp mount*
SF18	TR-HSI HLO 700C	-	700C	63	HLO	COIL w/ Preload adjuster	475	44	AC4C	-	30	STKM	Cr-plating	108	1-1/8"(TS), STKM/ (OP) 1-1/8"(TS), Alloy/1.5"to1-1/8" tapered(CTS), Alloy	9-100	9mm-Dropout	Mg	-	HSI	-

*Small size type on the center of brace

NCX32

32-E AIR LO 29"



MODEL YEAR	MODEL NAME	MAIN SPECIFICATIONS								CROWN		STANCHION				STEERER TUBE	AXLE		BOTTOM CASE / BRAKE		
		Weight (g) w/o axle	Wheel	Travel (mm)	Damper	Spring	Axle to crown (mm)	Offset (mm)	Mat.	Method	DIA (mm)	Mat.	Finish	Pitch (mm)	Size Material	O.L.D.	Axle	Mat.	Max rotor DIA.	Brake mount	Note
SF21	NCX32-E-AIR RL DS 29"	-	29"x2.25"	63/75	RL	AIR	493	46	AC4C	-	32	Alloy	Hard anodized, Black	126	1.5"to 1-1/8" tapered(CTS), STKM/ (OP) 1.5"to 1-1/8" tapered(CTS), Alloy	9-100	9mm-Dropout	Mg	180mm	Post 160 Direct	with lamp mount*
SF21	NCX32-E-AIR LO DS 29"	2180	29"x2.25"	63/75	LO	AIR	493	46	AC4C	-	32	Alloy	Hard anodized, Black	126	1.5"to 1-1/8" tapered(CTS), STKM/ (OP) 1.5"to 1-1/8" tapered(CTS), Alloy	9-100	9mm-Dropout	Mg	180mm	Post 160 Direct	with lamp mount*
SF21	NCX32-E-AIR RL DS 27.5"	-	27.5"x2.25"	63/75	RL	AIR	477	46	AC4C	-	32	Alloy	Hard anodized, Black	126	1.5"to 1-1/8" tapered(CTS), STKM/ (OP) 1.5"to 1-1/8" tapered(CTS), Alloy	9-100	9mm-Dropout	Mg	180mm	Post 160 Direct	with lamp mount*
SF21	NCX32-E-AIR LO DS 27.5"	2120	27.5"x2.25"	63/75	LO	AIR	477	46	AC4C	-	32	Alloy	Hard anodized, Black	126	1.5"to 1-1/8" tapered(CTS), STKM/ (OP) 1.5"to 1-1/8" tapered(CTS), Alloy	9-100	9mm-Dropout	Mg	180mm	Post 160 Direct	with lamp mount*
SF21	NCX32-E-COIL RL DS 29"	-	29"x2.25"	63/75	RL	COIL w/ Preload adjuster	493	46	AC4C	-	32	Alloy	Hard anodized, Black	126	1.5"to 1-1/8" tapered(CTS), STKM/ (OP) 1.5"to 1-1/8" tapered(CTS), Alloy	9-100	9mm-Dropout	Mg	180mm	Post 160 Direct	with lamp mount*
SF21	NCX32-E-COIL LO DS 29"	-	29"x2.25"	63/75	LO	COIL w/ Preload adjuster	493	46	AC4C	-	32	Alloy	Hard anodized, Black	126	1.5"to 1-1/8" tapered(CTS), STKM/ (OP) 1.5"to 1-1/8" tapered(CTS), Alloy	9-100	9mm-Dropout	Mg	180mm	Post 160 Direct	with lamp mount*
SF21	NCX32-E-COIL RL DS 27.5"	-	27.5"x2.25"	63/75	RL	COIL w/ Preload adjuster	477	46	AC4C	-	32	Alloy	Hard anodized, Black	126	1.5"to 1-1/8" tapered(CTS), STKM/ (OP) 1.5"to 1-1/8" tapered(CTS), Alloy	9-100	9mm-Dropout	Mg	180mm	Post 160 Direct	with lamp mount*
SF21	NCX32-E-COIL LO DS 27.5"	-	27.5"x2.25"	63/75	LO	COIL w/ Preload adjuster	477	46	AC4C	-	32	Alloy	Hard anodized, Black	126	1.5"to 1-1/8" tapered(CTS), STKM/ (OP) 1.5"to 1-1/8" tapered(CTS), Alloy	9-100	9mm-Dropout	Mg	180mm	Post 160 Direct	with lamp mount*

*Front face on fork crown

32-D COIL LO 29"



TREKKING

NCX32

MODEL YEAR	MODEL NAME	MAIN SPECIFICATIONS							CROWN		STANCHION				STEERER TUBE		AXLE		BOTTOM CASE / BRAKE		
		Weight (g) w/o axle	Wheel	Travel (mm)	Damper	Spring	Axle to crown (mm)	Offset (mm)	Mat.	Method	DIA (mm)	Mat.	Finish	Pitch (mm)	Size Material	O.L.D.	Axle	Mat.	Max rotor DIA.	Brake mount	Note
SF21	NCX32-D-COIL RL DS 29"	-	29"x2.25"	63/75	RL	COIL w/ Preload adjuster	493	46	AC4C	-	32	STKM	Ni-plating	126	1.5"to1-1/8" tapered(CTS), STKM/ (OP) 1.5"to1-1/8" tapered(CTS), Alloy	9-100	9mm-Dropout	Mg	180mm	Post 160 Direct	with lamp mount*
SF21	NCX32-D-COIL LO DS 29"	2560	29"x2.25"	63/75	LO	COIL w/ Preload adjuster	493	46	AC4C	-	32	STKM	Ni-plating	126	1.5"to1-1/8" tapered(CTS), STKM/ (OP) 1.5"to1-1/8" tapered(CTS), Alloy	9-100	9mm-Dropout	Mg	180mm	Post 160 Direct	with lamp mount*
SF21	NCX32-D-COIL RL DS 27.5"	-	27.5"x2.25"	63/75	RL	COIL w/ Preload adjuster	477	46	AC4C	-	32	STKM	Ni-plating	126	1.5"to1-1/8" tapered(CTS), STKM/ (OP) 1.5"to1-1/8" tapered(CTS), Alloy	9-100	9mm-Dropout	Mg	180mm	Post 160 Direct	with lamp mount*
SF21	NCX32-D-COIL LO DS 27.5"	2500	27.5"x2.25"	63/75	LO	COIL w/ Preload adjuster	477	46	AC4C	-	32	STKM	Ni-plating	126	1.5"to1-1/8" tapered(CTS), STKM/ (OP) 1.5"to1-1/8" tapered(CTS), Alloy	9-100	9mm-Dropout	Mg	180mm	Post 160 Direct	with lamp mount*

*Front face on fork crown

SPECIFICATIONS

// 2022



NLO 29"



MODEL YEAR	MODEL NAME	MAIN SPECIFICATIONS							CROWN		STANCHION				STEERER TUBE	AXLE		BOTTOM CASE / BRAKE			
		Weight (g) w/o axle	Wheel (mm)	Travel (mm)	Damper	Spring	Axle to crown (mm)	Offset (mm)	Mat.	Method	DIA (mm)	Mat.	Finish	Pitch (mm)	Size Material	O.L.D.	Axle	Mat.	Max rotor DIA.	Brake mount	Note
SF22	NVX30 RL DS 29"	-	29"	63/80 100	RL	COIL w/ Preload adjuster	492	46	AC4C	-	30	STKM	Cr-plating	126	1-1/8"(TS), STKM	9-100	9mm-Dropout	Al	180mm	Post 160 Direct	with lamp mount*
SF22	NVX30 NLO DS 29"	3050	29"	63/80 100	NLO	COIL w/ Preload adjuster	492	46	AC4C	-	30	STKM	Cr-plating	126	1-1/8"(TS), STKM	9-100	9mm-Dropout	Al	180mm	Post 160 Direct	with lamp mount*
SF22	NVX30 DS 29"	-	29"	63/80 100	-	COIL w/ Preload adjuster	492	46	AC4C	-	30	STKM	Cr-plating	126	1-1/8"(TS), STKM	9-100	9mm-Dropout	Al	180mm	Post 160 Direct	with lamp mount*
SF22	NVX30 RL DS 27.5"	-	27.5"	63/80 100	RL	COIL w/ Preload adjuster	479	46	AC4C	-	30	STKM	Cr-plating	126	1-1/8"(TS), STKM	9-100	9mm-Dropout	Al	180mm	Post 160 Direct	with lamp mount*
SF22	NVX30 NLO DS 27.5"	-	27.5"	63/80 100	NLO	COIL w/ Preload adjuster	479	46	AC4C	-	30	STKM	Cr-plating	126	1-1/8"(TS), STKM	9-100	9mm-Dropout	Al	180mm	Post 160 Direct	with lamp mount*
SF22	NVX30 DS 27.5"	-	27.5"	63/80 100	-	COIL w/ Preload adjuster	479	46	AC4C	-	30	STKM	Cr-plating	126	1-1/8"(TS), STKM	9-100	9mm-Dropout	Al	180mm	Post 160 Direct	with lamp mount*

*Front face on fork crown

E25-C NLO 700C



MODEL YEAR	MODEL NAME	MAIN SPECIFICATIONS							CROWN		STANCHION		STEERER TUBE		AXLE		BOTTOM CASE / BRAKE				
		Weight (g) w/o axle	Wheel	Travel (mm)	Damper	Spring	Axle to crown (mm)	Offset (mm)	Mat.	Method	DIA (mm)	Mat.	Finish	Pitch (mm)	Size Material	O.L.D.	Axle	Mat.	Max rotor DIA.	Brake mount	Note
SF19	NEX-E25-C NLO DS 15QLC32 700C	2655	700C	50/63 75	NLO	COIL w/ Preload adjuster	491	44	AC4C	-	30	STKM	Cr-plating	116	1-1/8"(TS), STKM/ (OP) 1.5"to1-1/8" tapered(CTS), STKM	ø15-100	15QLC32S	Al	180mm	Post 160 Direct	with lamp mount*
SF18	NEX-E25-C DS 15QLC32 700C	2655	700C	50/63 75	-	COIL w/ Preload adjuster	491	44	AC4C	-	30	STKM	Cr-plating	116	1-1/8"(TS), STKM/ (OP) 1.5"to1-1/8" tapered(CTS), STKM	ø15-100	15QLC32S	Al	180mm	Post 160 Direct	with lamp mount*
SF19	NEX-E25 NLO DS 15QLC32 700C	2655	700C	50/63 75	NLO	COIL w/ Preload adjuster	491	44	AC4C	-	30	STKM	Cr-plating	116	1-1/8"(TS), STKM/ (OP) 1.5"to1-1/8" tapered(CTS), STKM	ø15-100	15QLC32S	Al	180mm	Post 160 Direct	with lamp mount**
SF17	NEX-E25 DS 15QLC32 700C	2655	700C	50/63 75	-	COIL w/ Preload adjuster	491	44	AC4C	-	30	STKM	Cr-plating	116	1-1/8"(TS), STKM/ (OP) 1.5"to1-1/8" tapered(CTS), STKM	ø15-100	15QLC32S	Al	180mm	Post 160 Direct	with lamp mount**
SF19	NEX-E25 NLO DS 700C	-	700C	50/63 75	NLO	COIL w/ Preload adjuster	489	44	AC4C	-	30	STKM	Cr-plating	116	1-1/8"(TS), STKM/ (OP) 1.5"to1-1/8" tapered(CTS), STKM	9-100	9mm-Dropout	Al	180mm	Post 160 Direct	with lamp mount**
SF19	NEX-E25 NLO P 700C	-	700C	50/63 75	NLO	COIL w/ Preload adjuster	489	44	AC4C	-	30	STKM	Cr-plating	116	1-1/8"(TS), STKM/ (OP) 1.5"to1-1/8" tapered(CTS), STKM	9-100	9mm-Dropout	Al	180mm	V-Brake+Post	with lamp mount**
SF15	NEX-E25 DS 700C	2420	700C	50/63 75	-	COIL w/ Preload adjuster	489	44	AC4C	-	30	STKM	Cr-plating	116	1-1/8"(TS), STKM/ (OP) 1.5"to1-1/8" tapered(CTS), STKM	9-100	9mm-Dropout	Al	180mm	Post 160 Direct	with lamp mount**
SF14	NEX-E25 P 700C	-	700C	50/63 75	-	COIL w/ Preload adjuster	489	44	AC4C	-	30	STKM	Cr-plating	116	1-1/8"(TS), STKM/ (OP) 1.5"to1-1/8" tapered(CTS), STKM	9-100	9mm-Dropout	Al	180mm	V-Brake+Post	with lamp mount**
SF19	NEX-E25 P+DS NLO 26"	-	26"	50/63	NLO	COIL w/ Preload adjuster	443	44	AC4C	-	30	STKM	Cr-plating	116	1-1/8"(TS), STKM/ (OP) 1.5"to1-1/8" tapered(CTS), STKM	9-100	9mm-Dropout	Al	180mm	V-Brake+Post	with lamp mount**
SF18	NEX-E25 P+DS 26"	-	26"	50/63	-	COIL w/ Preload adjuster	443	44	AC4C	-	30	STKM	Cr-plating	116	1-1/8"(TS), STKM/ (OP) 1.5"to1-1/8" tapered(CTS), STKM	9-100	9mm-Dropout	Al	180mm	V-Brake+Post	with lamp mount**

*Small size type on the center position of crown / **Small size type on the center position of fork brace



MODEL YEAR	MODEL NAME	MAIN SPECIFICATIONS							CROWN		STANCHION				STEERER TUBE	AXLE		BOTTOM CASE / BRAKE			
		Weight (g) w/o axle	Wheel	Travel (mm)	Damper	Spring	Axle to crown (mm)	Offset (mm)	Mat.	Method	DIA (mm)	Mat.	Finish	Pitch (mm)	Size Material	O.L.D.	Axle	Mat.	Max rotor DIA.	Brake mount	Note
SF20	NEX RL DS 700C	2655	700C	50/63	RL	COIL w/ Preload adjuster	472	42	AC4C	-	28	STKM	Cr-plating	116	1-1/8"(TS), STKM	9-100	9mm-Dropout	Al	180mm	Post 160 Direct	with lamp mount*
SF20	NEX RL P 700C	2320	700C	50/63	RL	COIL w/ Preload adjuster	472	42	AC4C	-	28	STKM	Cr-plating	116	1-1/8"(TS), STKM	9-100	9mm-Dropout	Al	-	V-Brake	with lamp mount*
SF20	NEX HLO DS 700C	2669	700C	50/63	HLO	COIL w/ Preload adjuster	472	42	AC4C	-	28	STKM	Cr-plating	116	1-1/8"(TS), STKM	9-100	9mm-Dropout	Al	180mm	Post 160 Direct	with lamp mount*
SF20	NEX HLO P 700C	-	700C	50/63	HLO	COIL w/ Preload adjuster	472	42	AC4C	-	28	STKM	Cr-plating	116	1-1/8"(TS), STKM	9-100	9mm-Dropout	Al	-	V-Brake	with lamp mount*
SF20	NEX DS 700C	2420	700C	50/63	-	COIL w/ Preload adjuster	472	42	AC4C	-	28	STKM	Cr-plating	116	1-1/8"(TS), STKM	9-100	9mm-Dropout	Al	180mm	Post 160 Direct	with lamp mount*
SF20	NEX P 700C	-	700C	50/63	-	COIL w/ Preload adjuster	472	42	AC4C	-	28	STKM	Cr-plating	116	1-1/8"(TS), STKM	9-100	9mm-Dropout	Al	-	V-Brake	with lamp mount*
SF21	NEX HLO DS 26"	2504	26"	50/63	HLO	COIL w/ Preload adjuster	450	40	AC4C	-	28	STKM	Cr-plating	116	1-1/8"(TS), STKM	9-100	9mm-Dropout	Al	180mm	Post 160 Direct	with lamp mount*
SF21	NEX DS 26"	2305	26"	50/63	-	COIL w/ Preload adjuster	450	40	AC4C	-	28	STKM	Cr-plating	116	1-1/8"(TS), STKM	9-100	9mm-Dropout	Al	180mm	Post 160 Direct	with lamp mount*
SF21	NEX P 26"	-	26"	63	-	COIL w/ Preload adjuster	450	40	AC4C	-	28	STKM	Cr-plating	116	1-1/8"(TS), STKM	9-100	9mm-Dropout	Al	-	V-Brake	with lamp mount*

*Small size type on the center position of fork brace

CR85 E25 LO 700C



CR8V-P-700C



MODEL YEAR	MODEL NAME	MAIN SPECIFICATIONS							CROWN		STANCHION			STEERER TUBE		AXLE		BOTTOM CASE / BRAKE			
		Weight (g) w/o axle	Wheel	Travel (mm)	Damper	Spring	Axle to crown (mm)	Offset (mm)	Mat.	Method	DIA (mm)	Mat.	Finish	Pitch (mm)	Size Material	O.L.D.	Axle	Mat.	Max rotor DIA.	Brake mount	Note
SF14	CR85-E25 P LO 700C	2700	700C	50/63	LO	COIL w/ Preload adjuster	476	41	AC4C	-	30	STKM	Cr-plating	116	1-1/8"(TS), STKM	9-100	9mm-Dropout	Al	-	V-Brake	with lamp mount*
SF14	CR85-E25 P 700C	2485	700C	50/63	-	COIL w/ Preload adjuster	476	41	AC4C	-	30	STKM	Cr-plating	116	1-1/8"(TS), STKM	9-100	9mm-Dropout	Al	-	V-Brake	with lamp mount*
SF14	CR85-E25-R LO 700C	2655	700C	40	LO	COIL w/ Preload adjuster	453	41	AC4C	-	30	STKM	Cr-plating	116	1-1/8"(TS), STKM	9-100	9mm-Dropout	Al	-	Roller	with lamp mount*
SF14	CR85-E25 R 700C	2438	700C	40	-	COIL w/ Preload adjuster	453	41	AC4C	-	30	STKM	Cr-plating	116	1-1/8"(TS), STKM	9-100	9mm-Dropout	Al	-	Roller	with lamp mount*
SF18	CR85-E25 P LO 26"	-	26"	50	LO	COIL w/ Preload adjuster	445	41	AC4C	-	30	STKM	Cr-plating	116	1-1/8"(TS), STKM	9-100	9mm-Dropout	Al	-	V-Brake	with lamp mount*
SF18	CR85-E25 P 26"	-	26"	50	-	COIL w/ Preload adjuster	445	41	AC4C	-	30	STKM	Cr-plating	116	1-1/8"(TS), STKM	9-100	9mm-Dropout	Al	-	V-Brake	with lamp mount*
SF13	CR8-V HLO P 700C	2497	700C	50	HLO	COIL w/ Preload adjuster	463	45	AC4C	-	28	STKM	Cr-plating	108	1-1/8" (TS) STKM	9-100	9mm-Dropout	Al	-	V-brake	with lamp mount*
SF13	CR8-R HLO 700C	2365	700C	40	HLO	COIL w/ Preload adjuster	463	43	AC4C	-	28	STKM	Cr-plating	108	1-1/8" (TS) STKM	9-100	9mm-Dropout	Al	-	Roller	with lamp mount*
SF13	CR8-R 700C	2265	700C	50	-	COIL w/ Preload adjuster	463	43	AC4C	-	28	STKM	Cr-plating	108	1-1/8" (TS) STKM	9-100	9mm-Dropout	Al	-	Roller	with lamp mount*
SF13	CR8-V P 700C	2253	700C	50	-	COIL w/ Preload adjuster	463	43	AC4C	-	28	STKM	Cr-plating	108	1-1/8" (TS) STKM	9-100	9mm-Dropout	Al	-	V-brake	with lamp mount*
SF15	CR8-V HLO P 26"	2477	26"	50	HLO	COIL w/ Preload adjuster	445	45	AC4C	-	28	STKM	Cr-plating	108	1-1/8" (TS) STKM	9-100	9mm-Dropout	Al	-	V-brake	with lamp mount*
SF15	CR8-V P 26"	2377	26"	50	-	COIL w/ Preload adjuster	445	43	AC4C	-	28	STKM	Cr-plating	108	1-1/8" (TS) STKM	9-100	9mm-Dropout	Al	-	V-brake	with lamp mount*

*Small size type on the center position of fork brace

TRIAIR 1

DOWNHILL / FREERIDE / ENDURO / TRAIL



MODEL YEAR	MODEL NAME	WEIGHT (g)	DAMPER	TRAVEL (IMPERIAL)	TRAVEL (METRIC)	TRAVEL (TRUNNION)	SPRING	FEATURE
RS18	TRIAIR1-TR-3CR	403g (185x50)	3CR	-	-	185x50 mm, 185x55 mm, 205x60 mm, 205x65 mm, 225x70 mm, 225x75 mm	AIR	- Compression: 3 modes - Rebound: 8 clicks - Air Volume Spacer, IFP system.
RS18	TRIAIR1-3CR	400g (200x57) 402g (216x63)	3CR	200x57, 216x63,	210x50, 210x55, 230x65, 250x70, 250x75	-	AIR	- Compression: 3 modes - Rebound: 8 clicks - Air Volume Spacer, IFP system.

TRIAIR 2

DOWNHILL / FREERIDE / ENDURO / TRAIL



MODEL YEAR	MODEL NAME	WEIGHT (g)	DAMPER	TRAVEL (METRIC)	TRAVEL (TRUNNION)	SPRING	FEATURE
RS21	TRIAIR2-TR-3CR	-	3CR	210 x 50 / 55 mm, 230 x 60 / 65 mm, 250 x 70 / 75 mm	-	AIR	- High flow piston - Increased high flow steel shaft, diameter 10mm
RS21	TRIAIR2-TR-2CR	-	2CR	210 x 50 / 55 mm, 230 x 60 / 65 mm, 250 x 70 / 75 mm	-	AIR	- Reinforced main body, 27mm diameter - 15mm IGUS bushings, Mounting hard-ware w/6,8,10 mm
RS21	TRIAIR2-TR-R	-	R	210 x 50 / 55 mm, 230 x 60 / 65 mm, 250 x 70 / 75 mm	-	AIR	- 15mm IGUS bushings, Mounting hard-ware w/6,8,10 mm
RS21	TRIAIR2-3CR	-	3CR	-	185 x 50 / 55 mm, 205 x 60 / 65 mm, 225 x 70 / 75 mm	AIR	- High flow piston - Increased high flow steel shaft, diameter 10mm
RS21	TRIAIR2-2CR	-	2CR	-	185 x 50 / 55 mm, 205 x 60 / 65 mm, 225 x 70 / 75 mm	AIR	- Reinforced main body, 27mm diameter - 15mm IGUS bushings, Mounting hard-ware w/6,8,10 mm
RS21	TRIAIR2-R	-	R	-	185 x 50 / 55 mm, 205 x 60 / 65 mm, 225 x 70 / 75 mm	AIR	- 15mm IGUS bushings, Mounting hard-ware w/6,8,10 mm

EDGE PLUS ENDURO / TRAIL / CROSS COUNTRY



MODEL YEAR	MODEL NAME	WEIGHT (g)	DAMPER	TRAVEL (INCH)	TRAVEL (METRIC)	TRAVEL (TRUNNION)	SPRING	FEATURE
RS21	EDGE-PLUS-2CR	359g (230x60/65)	2CR	152 x 31 mm, 165 x 38 mm, 184 x 44 mm, 190 x 51 mm, 200 x 51 / 57 mm	170 x 30 / 35 mm 190 x 40 / 45 mm 210 x 50 / 55 mm 230 x 60 / 65mm	-	AIR	Air spring with bigger air volume
RS21	EDGE-PLUS-RC	-	RC	152 x 31 mm, 165 x 38 mm, 184 x 44 mm, 190 x 51 mm, 200 x 51 / 57 mm	170 x 30 / 35 mm 190 x 40 / 45 mm 210 x 50 / 55 mm	-	AIR	Air spring with bigger air volume
RS21	EDGE-PLUS-R	-	R	152 x 31 mm, 165 x 38 mm, 184 x 44 mm, 190 x 51 mm, 200 x 51 / 57 mm	170 x 30 / 35 mm 190 x 40 / 45 mm 210 x 50 / 55 mm	-	AIR	Air spring with bigger air volume
RS21	EDGE-PLUS-R-2CR	-	R-2CR	152 x 31 mm, 165 x 38 mm, 184 x 44 mm, 190 x 51 mm, 200 x 51 / 57 mm	170 x 30 / 35 mm 190 x 40 / 45 mm 210 x 50 / 55 mm	-	AIR	- Remote version - Air spring with bigger air volume
RS21	EDGE-PLUS-TR-2CR	-	2CR	-	-	145 x 30 / 35 mm, 165 x 40 / 45 mm, 185 x 50 / 55 mm	AIR	Air spring with bigger air volume
RS21	EDGE-PLUS-TR-RC	-	RC	-	-	145 x 30 / 35 mm, 165 x 40 / 45 mm, 185 x 50 / 55 mm	AIR	Air spring with bigger air volume
RS21	EDGE-PLUS-TR-R	-	R	-	-	145 x 30 / 35 mm, 165 x 40 / 45 mm, 185 x 50 / 55 mm	AIR	Air spring with bigger air volume
RS21	EDGE-PLUS-TR-R-2CR	-	R-2CR	-	-	145 x 30 / 35 mm, 165 x 40 / 45 mm, 185 x 50 / 55 mm	AIR	- Remote version - Air spring with bigger air volume

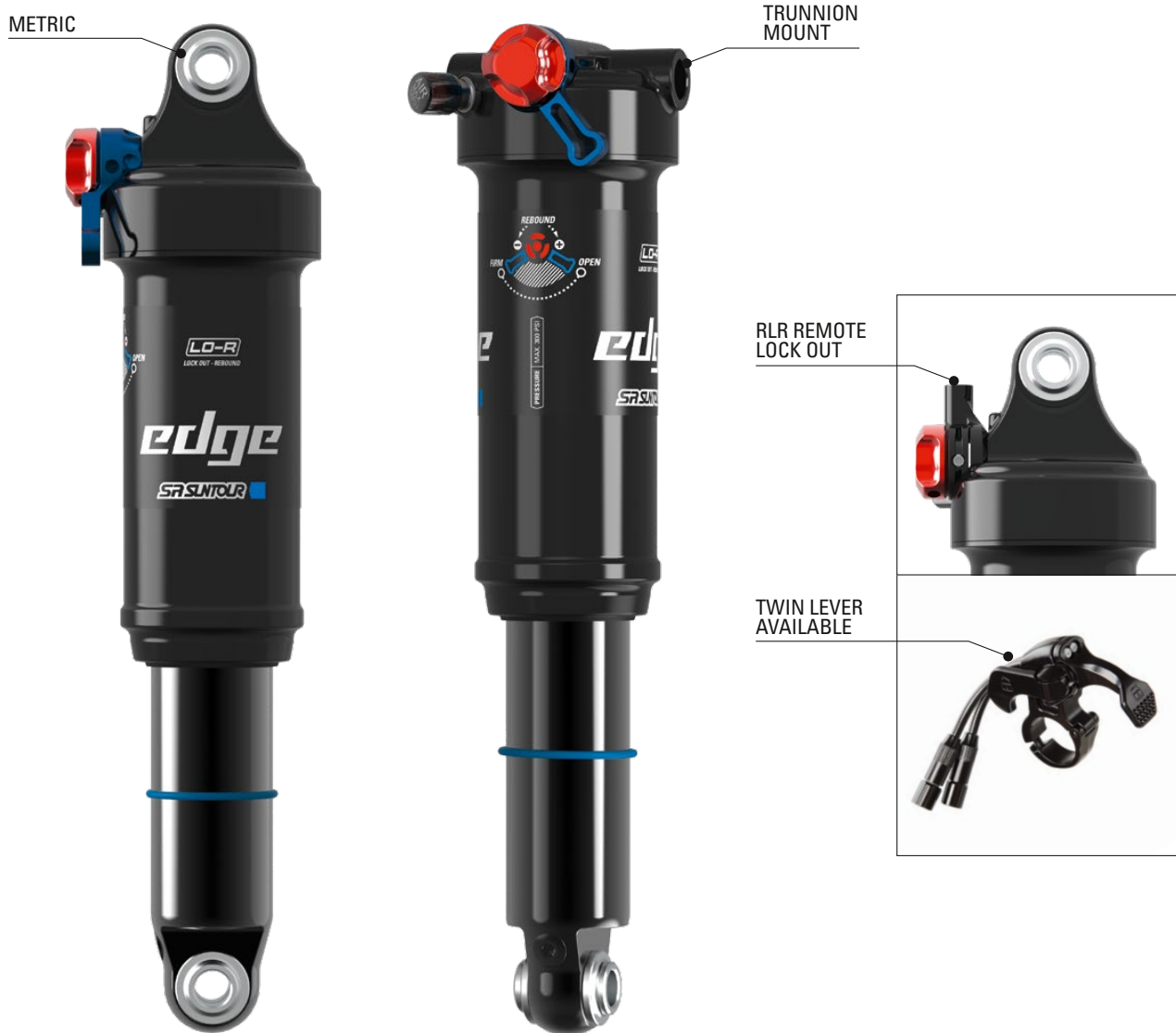

MODEL YEAR	MODEL NAME	WEIGHT (g)	DAMPER	TRAVEL (INCH)	TRAVEL (METRIC)	TRAVEL (TRUNNION)	SPRING	FEATURE
RS18	EDGE-LOR	-	LOR	152 x 31 mm, 165 x 38 mm, 184 x 44 mm, 190 x 51 mm	170 x 30 / 35 mm 190 x 40 / 45 mm	-	AIR	-
RS18	EDGE-LOR8	-	LOR8	152 x 31 mm, 165 x 38 mm, 184 x 44 mm, 190 x 51 mm	170 x 30 / 35 mm 190 x 40 / 45 mm	-	AIR	Low Speed Rebound with Lock Out 80%
RS18	EDGE-RC	-	RC	152 x 31 mm, 165 x 38 mm, 184 x 44 mm, 190 x 51 mm	170 x 30 / 35 mm 190 x 40 / 45 mm	-	AIR	-
RS18	EDGE-R	-	R	152 x 31 mm, 165 x 38 mm, 184 x 44 mm, 190 x 51 mm	170 x 30 / 35 mm 190 x 40 / 45 mm	-	AIR	-
RS18	EDGE-RLR	-	RLR	152 x 31 mm, 165 x 38 mm, 184 x 44 mm, 190 x 51 mm	170 x 30 / 35 mm 190 x 40 / 45 mm	-	AIR	Remote version
RS18	EDGE-RLR8	-	RLR8	152 x 31 mm, 165 x 38 mm, 184 x 44 mm, 190 x 51 mm	170 x 30 / 35 mm 190 x 40 / 45 mm	-	AIR	- Remote version - Low Speed Rebound with Lock Out 80%
RS18	EDGE-TR-LOR	-	LOR	-	-	145 x 30 / 35 mm, 165 x 40 / 45 mm, 185 x 50 / 55 mm	AIR	-
RS18	EDGE-TR-LOR8	-	LOR8	-	-	145 x 30 / 35 mm, 165 x 40 / 45 mm, 185 x 50 / 55 mm	AIR	Low Speed Rebound with Lock Out 80%
RS18	EDGE-TR-RC	-	RC	-	-	145 x 30 / 35 mm, 165 x 40 / 45 mm, 185 x 50 / 55 mm	AIR	-
RS18	EDGE-TR-R	-	R	-	-	145 x 30 / 35 mm, 165 x 40 / 45 mm, 185 x 50 / 55 mm	AIR	-
RS18	EDGE-TR-RLR	-	RLR	-	-	145 x 30 / 35 mm, 165 x 40 / 45 mm, 185 x 50 / 55 mm	AIR	Remote version
RS18	EDGE-TR-RLR8	-	RLR8	-	-	145 x 30 / 35 mm, 165 x 40 / 45 mm, 185 x 50 / 55 mm	AIR	- Remote version - Low Speed Rebound with Lock Out 80%

RAIDON TRAIL / CROSS COUNTRY



MODEL YEAR	MODEL NAME	WEIGHT (g)	DAMPER	TRAVEL (INCH)	TRAVEL (METRIC)	TRAVEL (TRUNNION)	SPRING	FEATURE
RS20	RAIDON LO	starting from 267g	LO	152 x 31 mm, 165 x 38 mm, 184 x 44 mm, 190 x 51 mm	170 x 30 / 35 mm 190 x 40 / 45 mm	-	AIR	New Appearance Design
RS20	RAIDON R	-	R	152 x 31 mm, 165 x 38 mm, 184 x 44 mm, 190 x 51 mm	170 x 30 / 35 mm 190 x 40 / 45 mm	-	AIR	New Appearance Design

NCX SUSPENSION SEATPOST URBAN / UTILITY



MODEL YEAR	MODEL NAME	TRAVEL	LENGTH	DESCRIPTION	SPRING	SPRING OPTION	POST SIZE	SEAT CLAMP
SP12	NCX-COIL	50 mm	350 mm	Brass bushing parallelogram	Internal Coil w/ preload adjust	Hard spring Soft spring	DIA. 27.2 mm w/ 25 mm setback	Slide clamp, radial detent, wide angle range
SP12	NCX-COIL	50 mm	350 mm	Brass bushing parallelogram	Internal Coil w/ preload adjust	Hard spring Soft spring	DIA. 31.6 mm w/ 25 mm setback	Slide clamp, radial detent, wide angle range
SP12	NCX-COIL	50 mm	400 mm	Brass bushing parallelogram	Internal Coil w/ preload adjust	Hard spring Soft spring	DIA. 27.2 mm w/ 25 mm setback	Slide clamp, radial detent, wide angle range
SP12	NCX-COIL	50 mm	400 mm	Brass bushing parallelogram	Internal Coil w/ preload adjust	Hard spring Soft spring	DIA. 31.6 mm w/ 25 mm setback	Slide clamp, radial detent, wide angle range
SP17	NCX-COIL	50 mm	400 mm	Brass bushing parallelogram	Internal Coil w/ preload adjust	Hard spring Soft spring	DIA. 30.9 mm w/ 25 mm setback	Slide clamp, radial detent, wide angle range
SP17	NCX-COIL	50 mm	350 mm	Brass bushing parallelogram	Internal Coil w/ preload adjust	Hard spring Soft spring	DIA. 30.9 mm w/ 25 mm setback	Slide clamp, radial detent, wide angle range



SERVICE DEALER NETWORK

BLESSED BY SR SUNTOUR TUNING BASE

The SR SUNTOUR Service Dealer Network has been developed in line with our Quick Service Product philosophy, ensuring that it's as easy as possible for local dealers to maintain and service our products. In combination with individual dealer training, we are able to offer you the highest level of local service with competent and effective customer service. This is guaranteed through a permanent stock of essential spare parts which every Service Dealer carries. Regardless of whether it's the service or maintenance of your fork, first-time buyer consultation, old equipment or new, or in-depth enquiries about SR SUNTOUR products, the Service Dealer Network is there for you.



www.srsuntour.com/service



SR SUNTOUR SPECIAL SERVICE TOOLS



SR SUNTOUR MAGIC WRENCH
(ZFC173)



SR SUNTOUR PROFESSIONAL MICROMETER ADJUSTABLE TORQUE WRENCH (ZFC161)



MTB ALLOY TOP CAP BOX WRENCH
27mm (ZFC160-R) / Trekking alloy top cap box wrench 21mm (ZFC159-R)

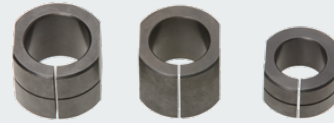

VICE CARTRIDGE CLAMPS
(FAT112)



SR SUNTOUR CANTILEVER BOSS REMOVER
(FAT120)



PLASTIC PRELOAD ADJUSTER CAP TOOL for 3/8" ratchets (FAT110 & FAT111)



DUST SEAL INSTALLER
for 38mm (FAT106), 36mm (FAT105), 35mm (FAT104), 34mm (FAT103), 32mm (FAT102) and 30mm (FAT101) stanchions



TOOL KIT BOX (FKA115) with dust seal installer for 38mm (FAT106), 36mm (FAT105), 35mm (FAT104), 34mm (FAT103), 32mm (FAT102) and 30mm (FAT101) stanchions, vice cartridge clamps (FAT112)



PRELOAD ADJUSTER REMOVER
for Trekking and MTB. Special plastic tool to open preload adjuster caps. (FAA122 & FAA086)



SERVICE KITS
available under www.srsuntour.us



HIGH PERFORMANCE SYNTHETIC GREASE
low friction grease for suspension forks and rear shocks lubrication, 350g



EXTRA LONG ALLEN WRENCH
350x5mm (ZFC021) / 350x6mm (ZFC171). Special tool for swing shock forks and bent design forks.

WEBSITE & SOCIAL MEDIA GUIDE

CORPORATE WEBSITE

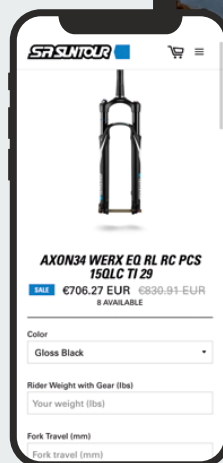
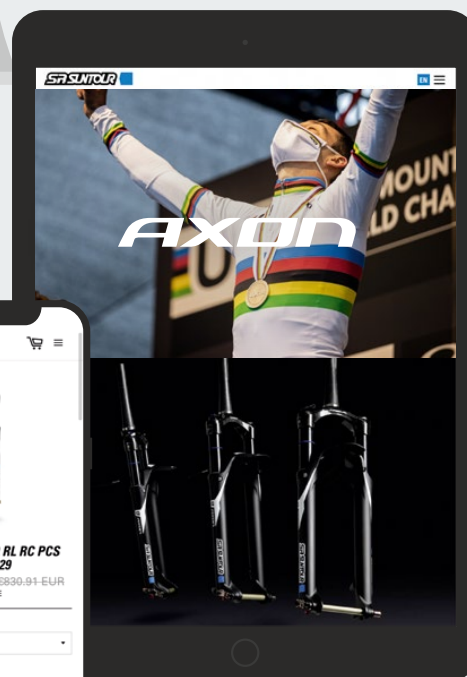
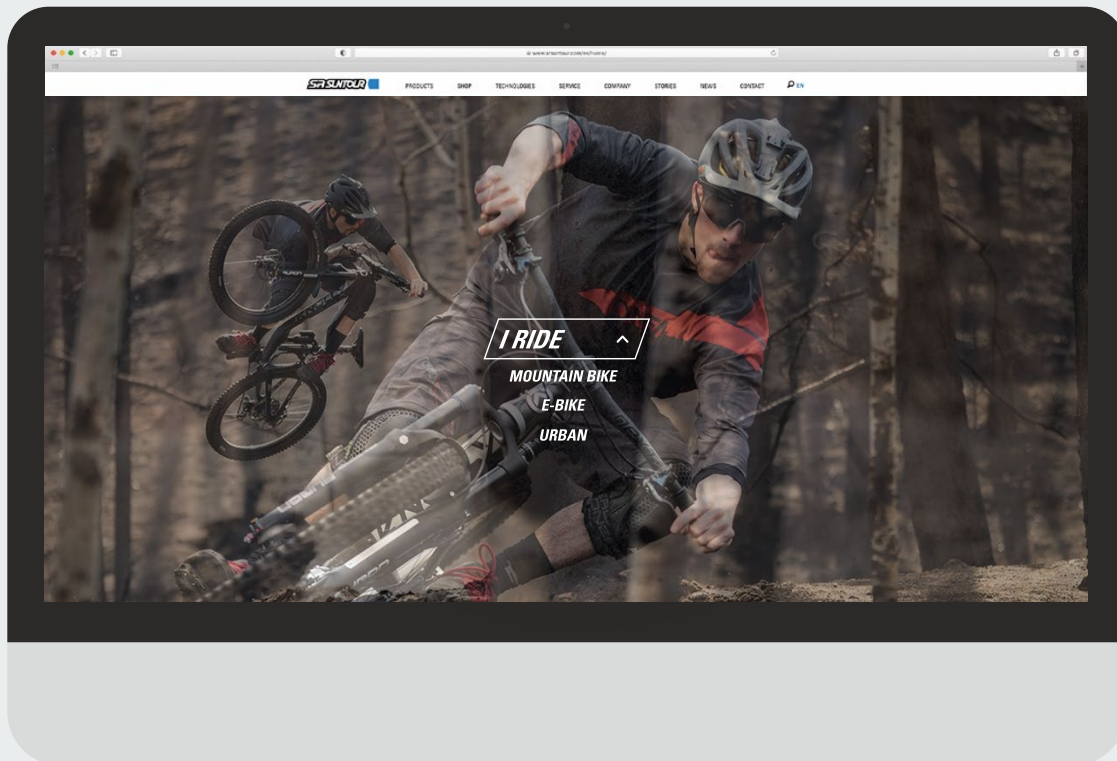

WWW.SRSUNTOUR.COM

- Product and event news
- Fork Identification Tool
- Service (Tech Videos, Service Request, Product Registration, Service Network, Fork Glossary)
- New Videos
- Worldwide contact information (Headquarters, Subsidiaries, Distributors)
- Download area: 3D exploded views, Owners manuals, Workshop books, Videos, E-Bike-Service
- Dealer Download Area - on demand



SOCIAL MEDIA

**NEW
FACEBOOK
ACCOUNT!**

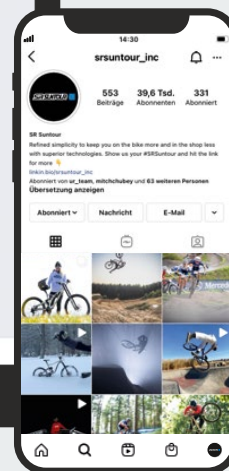
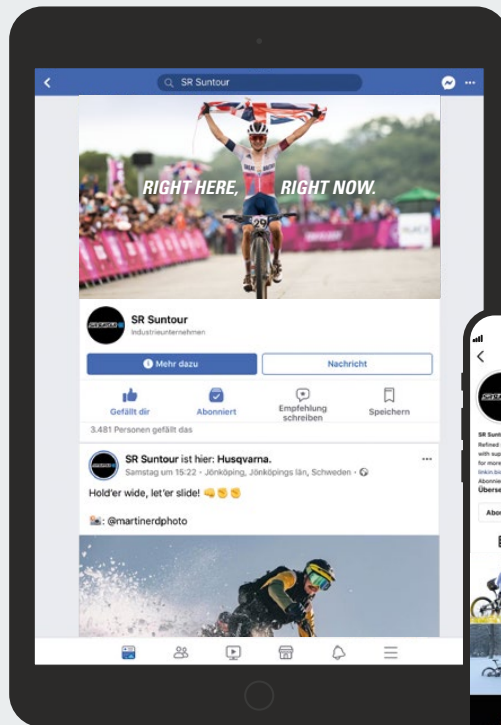

FACEBOOK: www.facebook.com/srsuntourinc

INSTAGRAM: www.instagram.com/srsuntour_inc

VIDEO

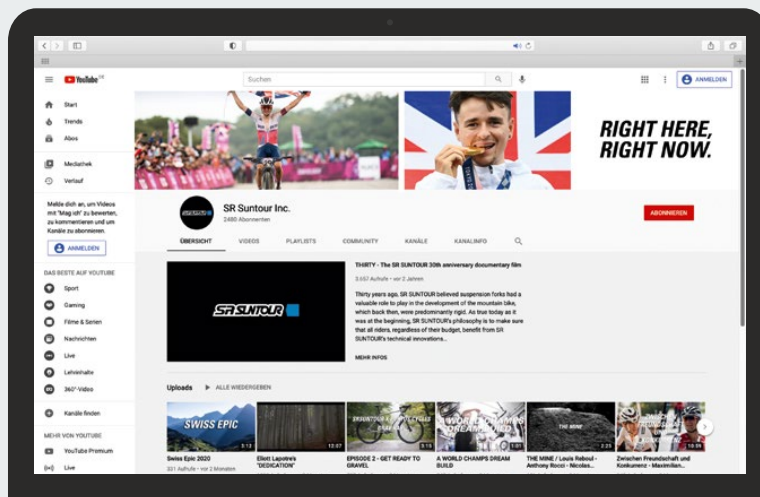

YOUTUBE CHANNEL: goo.gl/2tupiU

- Tech manual videos
- Action videos
- Product promotion videos

WORLDWIDE DISTRIBUTORS & SUBSIDIARIES

ARGENTINA

DAL SANTO IND. & COM. S.A.
Otto Krausse 4551 (C.p.:1667)
Entre Eiffel y Volta
Area de Promocion el Triangulo -
Tortuguitas
Malvinas Argentinas, Buenos Aires
TEL: +54 11 03327-455400
ventas@dalsanto.com.ar

ARMENIA

DREAMLAND BIKE - DLB
SERVICE CENTER
Leningradyan 4/12
0038 Yerevan
TEL: +374 010 3931 01
www.dlb.am

AUSTRALIA

BICYCLE PARTS WHOLESALE
76-80 Micro Circuit
Dandenong Vic. 3175
TEL: +61 3 9702 9044
service@bicyclepartswholesale.com.au

AUSTRIA

KTM FAHRRAD GMBH
Harlochner Str. 13
5230 Mattighofen
TEL: +43 7742 4091 6965
FAX: +43 7742 4094 26
service@ktm-bikes.at

BENELUX

TEHAVA INTERNATIONAL
Tomeikerweg 31
6161RB GELEEN
P.O Box 3009
6160 GA Geleen
TEL: +31 46 4752100
FAX: +31 464750424
srsuntour@tehava.com
www.tehava.com

BRAZIL

INTAC
Rue alba
1737-V.Santa Catarina
04346-000 Sao Paulo
TEL: +55 11 5565 2100
www.intac.com.br

MIX BICICLETAS INDÚSTRIA E COMÉRCIO LTDA.

Rua Robson Rufino Muniz, 970
Pq. Industrial - CEP 87111-676
Sarandi - Paraná
TEL: +55 44 3126 0000
comercial@mixbicicletas.com.br
www.mixbicicletas.com.br

CICLO CAIRU LTDA

Rua Cairu, 601 Sector Industrial,
76970-000
Pimenta Bueno, RO, Brazil
TEL: +55(69) 3451 0500
www.ciclocairu.com.br

BULGARIA

VELOMANIA LTD.
2E Akad. Ivan Geshov Blvd.
J.K. Hipodroma Bl.120 1330 1612 Sofia
TEL: + 359 2 812 7060
FAX: + 359 2 812 7061
info@velomania-bg.com
www.velomania-bg.com

CANADA

S4 SUSPENSION
801 Rue Pasteur, Local 108
Saint-Jerome Quebec J7Z 0E2
TEL: +450 504 1148
Gcaron@s4suspension.com
Jlaurier@s4suspension.com

CHINA

SRS INTERNATIONAL TRADING LTD.
Room 501,5th floor, building No.2
Jiaxing Industrial Zone, Suibei
road, Gongming town,Guangming
district,Shenzhen City China
ZIP 518106
TEL: +86 755 271 084 83
FAX: +86 755 271 606 29

SR SUNTOUR SERVICE CENTER- SHENZHEN

Room 501, 5th Floor, building No. 2
Jiaxing Industrial Zone, Suibei Road
Gongming town, Guangming District
Shenzhen City, China 518106
TEL: +86 755 271 084 83
FAX: +86 755 271 606 29

SR SUNTOUR (KUNSHAN)

International Co.Ltd.
No 1500 Honghu road,
Kunshan Development Zone
215333 P.R China
TEL: +86 512 55171127
sr-service@srsuntour.com.cn

CHILE

MAURICIO KISHINEVSKY
ROSENTAL S.A.
San Diego 1184
Casilla No. 285/3
Santiago
TEL: +56 2 555 5743
FAX: +56 2 555 2234
www.mkr.cl

COLOMBIA

HA BICICLETAS SA
Calle 14 No. 52A-187
Medellin, Colombia
TEL: +574 2 85 50 40
FAX: +574 2 55 33 43
ha@habicicletas.com
www.habicicletas.com

COSTA RICA

CICLO SAN NICOLAS, S.A.
Avenida 10, Calles 4 y 6,
150 metros este de Castellana,
San Jose, Costa Rica
TEL: +506 2521 6090
juan@distribuidorajf.com
www.ciclosannicolas.com

CROATIA

HUNI BIKE SHOP D.O.O.
Matije Gupca 92
40323 Prelog
(Hrvatska)
TEL: +385 40 645 033
tomislav@huni-bike-shop.hr
www.huni-bike-shop.hr

CZECH REPUBLIC

BP LUMEN
Puskinova 546
542 32 Upice
TEL: +420 499 881 327
FAX: +420 499 882 794
info@bplumen.cz
www.bplumen.cz

ECUADOR

AGUILA IMPORTACIONES
Av Mariano Acosta 15-46 y
Gabriela Mistral
TEL: +593 062 530 085
aguilaimportaciones@gmail.com
www.aguilaimportaciones.com

FRANCE

SR SUNTOUR FRANCE
SAV service + sales
Parc d'activités Alpespace
604 voie Galilée
73800 SAINTE HELENE DU LAC
TEL: +33 9 8124 1650
arnaud@srsuntour-cycling.com

WINORA FRANCE

TEL: 0800 64 65 66
FAX: +33 38 052 8122
contact@winora-group.com

GEORGIA

GO EXTREME TBILISI L.L.C.
Abashidze #51
0179, Vake
TEL: +99 5551 263 737
beka@bikes.ge
www.bikes.ge

GERMANY

E.WIENER BIKE PARTS GMBH
Max-Planck-Str. 4
97526 Sennfeld
Postfach 15 61, 97405 Schweinfurt
TEL: +49 9721 6501 88
FAX: +49 9721 6501 73

GREECE

CYCLOPILATIKI S.A
16 str, Str, Minotaurou, sfageia
Thessaloniki, 54627
TEL: +30 231 0461 035
FAX: +30 231 0462 003
info@cyclo.gr
www.ballistic.gr

HUNGARY

NEUZER KFT
H-1211 Budapest, Csepel Muvek,
Gyepsor UT 1
TEL: +361 420 3760
FAX: +361 420 0847
neuzer.info@neuzer-bike.hu
www.neuzer-bike.hu

INDONESIA

PRO BICYCLE
PASAR JUMAT NO 45 B , C
LEBAK BULUS
JAKARTA SELATAN
TEL: +6221 7663029
CELL: +6221 93010005
FAX: +6221 7663026
info@pro-bicycle.com
www.pro-bicycle.com



ITALY

ASSISTENZA RULLO
via A. Manzoni 368, 22070 Cassina
Rizzarda (co)
TEL: +39 31 934573
FAX: +39 31 934573
info@assistenzarullo.com

JAPAN

SR SUNTOUR JAPAN
NR Bldg. 4F, 3-13-13 Kuramae
Taito-ku
Tokyo, 111-0051
TEL: +81 3 5829 9211
FAX: +81 3 5829 9241

RITEWAY PRODUCTS JAPAN

3-18-34-102 Minami Ikebukuro
Toshima-ku, Tokyo
Tel: +81 3 5950 6002
Fax: +81 3 5956 8028
www.riteway-jp.com

LITHUANIA, LATVIA & ESTONIA

JW TRADE
Kreivoji g. 37
LT-78109 Siauliai
TEL: +370 604 18102
info@jwtrade.lt

MEXICO

BICICLETAS MERCURIO, S.A.
Carretera Central KM 422 s/n
Zona Industrial, San Luis Potosi
CP 78395
TEL: +52 (444) 144 2400
FAX: +52 (444) 144 2468
info.suntour@alubike.com.mx
www.windsorsportsgroup.com

NEW ZEALAND

MARLEEN WHOLESALERS LTD.
53 Treffers Road, Wigram Park
Christchurch City, Canterbury
TEL: +64 334 841 50
sales@marleen.co.nz
www.marleen.co.nz

NORWAY

BIKE ON NET AS
Ingvar Mjøsens vei 6
7340 Oppdal
TEL: +47 40 646 135
post@bikeonnet.no

PHILIPPINES

HATCH MARKETING
Quezon City 1113
TEL: +639 175 373 612
suntourphil@gmail.com

NEWTON MULTI SALES

689-D Del Monte Ave.
SFDIM, Quezon City
Metro Manila
TEL: +63 2372 5127
FAX: +63 2373 5439
nms1.cycle@gmail.com

POLAND

EURO BIKE PRODUCTS
ul. OSTROWSKA 498, 498A
61 324 Poznan
TEL: +48 61 87 05 107
FAX: +48 61 87 50 406
info@eurobike.pl
www.eurobike.pl

PORTUGAL

AGUESPORT - IMPORTACAO E EXPORTACAO LDA.
Zona Industrial de Barro (Este)
Apartado No. 5
3754-900 Barro
TEL: +351 234 690 310
FAX: +351 234 621 284
info@aguesport.com
www.aguesport.com

ROMANIA

S.C. VELOMANIA S.R.L.
Str. Nerva Traian nr. 12, Bl. M37,
Parter, Sect. 3, Bucuresti.
TEL: (004) 031 805 99 06
MOBILE: (004) 0726 170 324
s.negru@dragbicycles.com

NEUZER ROMANIA

540392, Str. Branului #33,
Targu Mures
TEL: +40 265 261 806
info@neuzer.ro
www.neuzer.ro

RUSSIA

ALNA-BIKE CO.
Sokolnicheskaya square 4
Moscow 107 113
TEL:/FAX: +7 495 775 14 09
Alna-Bike@mail.ru

SERBIA, BOSNIEN & HERZOGOVINA, MONTENEGRO, MACEDONIA

PLANET BIKE CO. DOO
Milosa Obilica 9-11
37000 Krusevac, Serbia
TEL: +381 37 420 000
info@planetbike.rs
www.planetbike.rs

SLOVAKIA

PAUL LANGE OSLANY S.R.O.
Mierová 854/37
972 47 Oslany
SLOVAK REPUBLIC
TEL: +421 465 492 344
office@paul-lange.sk
www.paul-lange.sk

SLOVENIA

PB BIKE CENTER MARIBOR
Erjavceva ulica 5, SI-2000 Maribor
TEL: +386 (02) 420 18 36
info@bike-center.si
www.bike-center.si

SOUTH AFRICA

DRAGONS SPORTS
15 Solan Road, Gardens,
8001 Cape Town
TEL: +27 21 461 6252
FAX: +27 21 461 9273
www.dragons.co.za

SPAIN

BH - BICICLETAS DE ALAVA BIKES EUROPE S.L.
C/ Perretagana 10
Poligono Industrial Jundiz
01015 Vitoria-Gasteiz
TEL: +34 (9)45 135202
FAX: +34 (9)45 139321/234810
alfonso@bhbikes.com
www.bhbikes.es

SWITZERLAND

WINORA GROUP
Accell Suisse AG
Industriestraße 21
CH - 6055 Alpnach
TEL: +41 41 544 04 95
srsuntour@winora-group.de
www.winora-group.de

TAIWAN

ACHIMAY ENTERPRISE CORPORATION
No. 486-8, Fuya Rd., Xitun Dist.,
Taichung City 407
Taiwan, R.O.C.
TEL: 04-24633258
achimay.tw@msa.hinet.net

THAILAND

LA BICYCLE (THAILAND) CO., LTD
58 Moo 2, Oam Yai, Sampran.
Nakornpathom 73160
TEL: +66 281 944 88
FAX: +66 281 266 85

TURKEY

KRON BISIKLET TIC. VE SAN. A.S.
Tepeoren Mah. Istanbul Tuzla Org.
San. Bolg. (Itosb)
7. Cadde No:11
34959 Tuzla/Istanbul, Turkey
TEL: +90-4446810
FAX: +90-2165931042
info@kronbisiklet.com.tr

UKRAINE

SPORT SYSTEMS
Kiev Region
Pershogo Travnja Str. 49
Novi Petrivci 07354
Vyshgorod District
TEL: +38 044 585 7035
FAX: +38 044 585 7036
vthkoryk@sportsys.com.ua

UNITED KINGDOM & IRELAND

GREYVILLE ENTERPRISES
20 Europa way britannia
enterprise park
Lichfield, Staffs. WS14 9TZ
TEL: +44 1543 251328
FAX: +44 1543 256260
sales@greyville.com

MOORE LARGE & CO. LTD

Derby DE24 9GL
Sinfine lane
Sinfine lane industrial estate
TEL: +44 1332 274 252
FAX: +44 1332 274 203
sales@moorelarge.co.uk

USA

LEXCO BIKE
7320 West Agatite Avenue
Norridge, IL 60706
TEL: +1 800 626 6556
FAX: +1 773 478 4584
www.lexcobike.com

QBP

6400 W. 105th Street
Bloomington, MN 55438
TEL: +1 800 346 0004
FAX: +1 800 346 0211
www.qbp.com

J&B IMPORTERS, INC

11925 SW 128th St.
Miami, FL 33186
TEL: +1 305 238 1866
www.jbimporters.com

OLYMPIC CYCLE SUPPLY

5711 W. Douglas Avenue
Milwaukee, WI 53218
TEL: +1 800 236 8380
FAX: +1 800 236 5606

Concept, Graphic design, layout
and photos by WHYEX
www.whyx.com
Art Direction: Tobias Guidone
Photography: Hoshi Yoshida, Rémy
Vroonen, Constantin Fiene, Philipp
Jülich, JP Gendron
Copyright © 2021 SR SUNTOUR inc.
All rights reserved. Specifications are
subject to change for improvement
without notice.

This catalogue depicts images of riding
and stunts performed by professional
riders under very strict control and
supervision. Avoid personal injury,
death or damage to your bicycle. Never
attempt to recreate or perform any
activity depicted in this catalogue.

SR SUNTOUR CORPORATE

TAIWAN HEADQUARTER

SR SUNTOUR INC.

#7 Hsing Yeh Road,
Fu Hsing Industrial Zone Chang Hua
Taiwan, R.O.C.
Tel: +886 (0)4-769-5115
Fax: +886 (0)4-769-4028
E-mail: service@srsuntour.com.tw

CHINA

SR SUNTOUR (Shen Zhen) INC.

Suibe Industrial Zone, Suibe Road,
Gongming Town Guangming District
Shen Zhen, China
Tel: +86-755-2710-5533
Fax: +86-755-2710-5633

SR SUNTOUR Machinery (Kunshan) Co. LTD

No.1500 Honghu Road, Penglang, Kunshan
Development Zone, Jiang Su Province
China ZIP 215333
Tel: +86-512-5518-8088
Fax: +86-512-5517-1113

VIETNAM

SR SUNTOUR Co. LTD

No.17-8, Street 3B,
Protrade International Tech Park,
An Tay commune, Ben Cat Town
Binh Duong Province, Vietnam
Tel: +84 (0)650-3721-883

EUROPE

SR SUNTOUR EUROPE GmbH

Sales, Customer Support and
Technical Services
Riedstrasse 31
83627 Warngau, Germany
Tel: +49 (0)802-150-793-0
Fax: +49 (0)802-150-793-29
Email: service@srsuntour-cycling.com

NORTH AMERICA

SR SUNTOUR North America Inc.

Ridgefield, Washington

Warranty, Service and Aftermarket Sales
7509 S 5th Street, Suite 124, Ridgefield,
Washington 98642, USA
Tel: +1 360-737-6450
Sales e-mail: ssna@srsuntourna.com
Service and warranty e-mail:
service@srsuntourna.com

Madison, Wisconsin

Warranty, Service, Sales and Marketing
910 Watson Avenue, Madison,
Wisconsin 53713, USA
Tel: +1 608-229-6610
Service and warranty e-mail:
service@usulcorp.com
Sales e-mail: sales@usulcorp.com

www.srsuntour.com

Printed in Germany 08-21

REFINED SIMPLICITY™

